VXI REVISION 1.4

OPERATOR'S MANUAL

2251A

UNIVERSAL TIMER/COUNTER

PUBLICATION NO. 980789

RACAL INSTRUMENTS

Racal Instruments, Inc.

4 Goodyear St., Irvine, CA 92718-2002
Tel: (800) RACAL-ATE, (949) 859- 8999, FAX: (949) 859-7309

Racal Instruments, Ltd.

480 Bath Road, Slough, Berkshire, SL1 6BE, United Kingdom
Tel: +44 (0) 1628 604455; FAX: +44 (0) 1628 662017

Racal Systems Electronique

18 Avenue Dutartre, 78150 LeChesnay, France
Tel: +33 (1) 3923 2222; FAX: +33 (1) 3923 2225

Racal Systems Elettronica Srl.

Strada 2-Palazzo C4, 20090 Milanofiori Assago, Milan, Italy
Tel: +39 (02) 5750 1796; FAX +39 (02) 5750 1828

Racal Elektronik System GmbH.

Frankenforster Strasse 21, 51427 Bergisch-Gladbach 1, Germany
Tel:+49 2204 92220; FAX: +49 2204 21491

Racal Australia Pty. Ltd.

3 Powells Road, Brookvale, NSW 2100, Australia
Tel: +61 (2) 9936 7000, FAX: +61 (2) 9936 7036

Racal Electronics Pte. Ltd.

26 Ayer Rajah Crescent, 04-06/07 Ayer Rajah Industrial Estate, Singapore 0513.
Tel: +65 7792200, FAX: +65 7785400

Racal Instruments, Ltd.

Room 1213 Nan Fung Centre, Tsuen Wan, New Territories, Hong Kong
Tel: +852 2405 5500, FAX: +852 2416 4335

<http://www.racalinst.com>

The RACAL logo consists of the word "RACAL" in a bold, sans-serif font. Each letter is contained within a rectangular box, and the boxes are slightly offset to create a 3D effect.

PUBLICATION DATE: SEPTEMBER 1998

Copyright 1998 by Racal Instruments, Inc. Printed in the United States of America. All rights reserved.
This book or parts thereof may not be reproduced in any form without written permission of the publisher.

WARRANTY STATEMENT

All Racal Instruments, Inc. products are designed and manufactured to exacting standards and in full conformance to Racal's ISO 9001 procedures.

For the specific terms of your standard warranty, or optional extended warranty or service agreement, contact your Racal customer service advisor. Please have the following information available to facilitate service.

1. Product serial number
2. Product model number
3. Your company and contact information

You may contact your customer service advisor by:

E-Mail:	Helpdesk@racalstruments.com	
Telephone:	+1 800 722 3262	(USA)
	+44(0) 8706 080134	(UK)
	+852 2405 5500	(Hong Kong)
Fax:	+1 949 859 7309	(USA)
	+44(0) 1628 662017	(UK)
	+852 2416 4335	(Hong Kong)

RETURN of PRODUCT

Authorization is required from Racal Instruments before you send us your product for service or calibration. Call your nearest Racal Instruments support facility. A list is located on the last page of this manual. If you are unsure where to call, contact Racal Instruments, Inc. Customer Support Department in Irvine, California, USA at 1-800-722-3262 or 1-949-859-8999 or via fax at 1-949-859-7139. We can be reached at: helpdesk@racalstruments.com.

PROPRIETARY NOTICE

This document and the technical data herein disclosed, are proprietary to Racal Instruments, and shall not, without express written permission of Racal Instruments, be used, in whole or in part to solicit quotations from a competitive source or used for manufacture by anyone other than Racal Instruments. The information herein has been developed at private expense, and may only be used for operation and maintenance reference purposes or for purposes of engineering evaluation and incorporation into technical specifications and other documents which specify procurement of products from Racal Instruments.

FOR YOUR SAFETY

Before undertaking any troubleshooting, maintenance or exploratory procedure, read carefully the **WARNINGS** and **CAUTION** notices.

This equipment contains voltage hazardous to human life and safety, and is capable of inflicting personal injury.

If this instrument is to be powered from the AC line (mains) through an autotransformer, ensure the common connector is connected to the neutral (earth pole) of the power supply.

Before operating the unit, ensure the conductor (green wire) is connected to the ground (earth) conductor of the power outlet. Do not use a two-conductor extension cord or a three-prong/two-prong adapter. This will defeat the protective feature of the third conductor in the power cord.

Maintenance and calibration procedures sometimes call for operation of the unit with power applied and protective covers removed. Read the procedures and heed warnings to avoid "live" circuit points.

Before operating this instrument:

1. Ensure the instrument is configured to operate on the voltage at the power source. See Installation Section.
2. Ensure the proper fuse is in place for the power source to operate.
3. Ensure all other devices connected to or in proximity to this instrument are properly grounded or connected to the protective third-wire earth ground.

If the instrument:

- fails to operate satisfactorily
- shows visible damage
- has been stored under unfavorable conditions
- has sustained stress

Do not operate until performance is checked by qualified personnel.

This page was left intentionally blank.

**OPERATORS MANUAL
TABLE OF CONTENTS**

MODEL 2251A

SECTION 1	GENERAL INFORMATION	1-1
1.1	Introduction	1-1
1.2	Measurement Functions	1-2
1.3	Input Signal Conditioning	1-3
1.4	Options	1-4
1.5	Performance Specifications	1-5
1.6	Definitions and Notes	1-14
1.7	Safety	1-17
1.8	Product Support	1-17
SECTION 2	INSTALLATION	2-1
2.1	Introduction	2-1
2.2	Unpacking and Inspection	2-1
2.3	Reshipment Instructions	2-1
2.4	Interrupt Level and Logical Address Setting	2-1
2.5	Installation	2-2
SECTION 3	USING THE INSTRUMENT	3-1
3.1	VXIbus Control	3-1
3.2	VXIbus Logical Address and Interrupt Level Assignment .	3-1
3.3	2251A Home State	3-2
3.4	Functional Check	3-3
3.5	Output Message Format	3-4
3.6	Input Commands	3-6
3.7	Selecting the Measurement Function	3-11
3.8	Numerical Input Data	3-12
3.9	Resolution Control Selection	3-13
3.10	Signal Conditional Parameters	3-14
3.11	Measurement Control Codes	3-15
3.12	Store and Recall Codes	3-16
3.13	Special Functions	3-17
3.14	2251A Supported IEEE-488.2 Commands	3-20
3.15	2251A IEEE-488.2 Status Reporting Structure Requirements	3-22
3.16	Device Dependent Status Bit (DDSB)	3-23
3.17	Error Messages	3-25

TABLE OF CONTENTS (Continued)

SECTION 4	PERFORMANCE VERIFICATION	4-1
4.1	Performance Verification Procedures (PVPs)	4-1
4.2	Functional Checks	4-14
4.3	Disassembly Instructions	4-17
4.4	Reassembly Instructions	4-17
4.5	2251A Input Amplifier Setup Procedure	4-18
SECTION 5	APPLICATION NOTES	5-1
5.1	Programming Defaults in Automatic Functions	5-1
5.2	Calculating Measurement Cycle Time	5-8
SECTION 6	OPTIONAL CABLE ASSEMBLIES	6-1
FIGURES		
1.1	2251A Resident In a VXIbus Compatible Mainframe	1-1
2.1	Location of Switches	2-2
3.1	IEEE-488.2 Status Reporting Model	3-22
4.1	Input A Low Frequency Sensitivity Test Configuration ...	4-3
4.2	Input A High Frequency Sensitivity Test Configuration ...	4-4
4.3	Input B Low Frequency Sensitivity Test Configuration ...	4-5
4.4	Input B High Frequency Sensitivity Test Configuration ...	4-6
4.5	Input C Test Configuration	4-7
4.6	Time Interval A-B Test Configuration	4-8
4.7	Totalize A by B Test Configuration	4-9
4.8	Ratio A/B Test Configuration	4-10
4.9	Ratio C/B Test Configuration	4-11
4.10	Input A Trigger Level Test Configuration	4-12
4.11	Input B Trigger Level Test Configuration	4-13
4.12	Input A Filter Check Configuration	4-14
4.13	Input A X10 Attenuator Check Configuration	4-15
4.14	Input B X10 Attenuator Check Configuration	4-16
4.15	Location of R10, R11, R12 and R15	4-18
4.16	Input A Amplifier Setup Configuration	4-19
4.17	Input B Amplifier Setup Configuration	4-20
4.18	Input C Setup Configuration	4-21
5.1	Positive/Negative Pulse	5-2
5.2	Rise/Fall Time	5-2
5.3	Phase Measurements	5-6

TABLE OF CONTENTS (Continued)

TABLES

3.1	2251A Home State	3-2
3.2	2251A Measurement Mode Output Strings	3-5
3.3	2251A Recalled Data Output Strings	3-6
3.4	Permitted Terminators	3-7
3.5	Instrument Preset Condition	3-8
3.6	Instrument Preset Code	3-9
3.7	Numerical Input Format	3-10
3.8	Measurement Function Codes	3-11
3.9	Numerical Input Ranges	3-12
3.10	Resolution Control Selection	3-13
3.11	Input Control Codes	3-14
3.12	Measurement Control Codes	3-15
3.13	Store and Recall Codes	3-16
3.14	Special Function Codes	3-18
3.15	Using the Special Function	3-19
3.16	IEEE-488.2 Command Codes	3-20
3.17	STA Related “Q” Codes	3-23
3.18	2251A STA Response Description	3-24
3.19	2251A STA Error Code Set	3-25
3.20	Alphabetical List of 2251A Command Codes	3-26
4.1	Input A Sensitivity Low Frequency Test	4-3
4.2	Input A Sensitivity High Frequency Performance Limits ..	4-4
4.3	Input B Sensitivity Low Frequency Performance Limits ..	4-5
4.4	Input B Sensitivity High Frequency Performance Limits ..	4-6
4.5	Input C Sensitivity Performance Limits	4-7
4.6	Time Interval A-B Test Performance Limits	4-8

1.1 Introduction

- 1.1.1 The Racal Instruments Universal Counter Timer Model 2251A is a microprocessor controlled instrument offering high resolution measurement capabilities. The 2251A is designed to be used under the direction of the Slot 0 System Resource Manager of a VXIbus compatible mainframe. The 2251A conforms to VXIbus System Specification Revision 1.4.
- 1.1.2 The measurement capabilities of the 2251A may be extended to include frequency measurements to 1.3 GHz with Option 41.
- 1.1.3 The 2251A is designed to be controlled remotely over the VXIbus. No local control of the counter is possible. The command set the counter responds to is defined by Racal Instruments. Refer to Section 3 of this manual for details of this command set.
- 1.1.4 Refer to **Figure 1-1** for an illustration of the 2251A in a VXI mainframe.

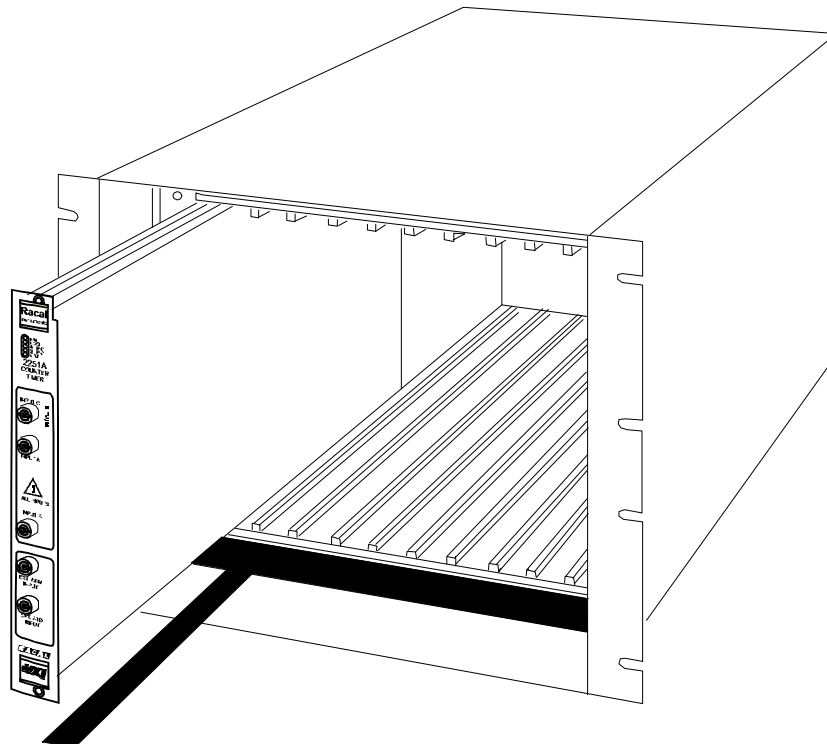

Figure 1-1. Model 2251A Resident In a VXIbus Compatible Mainframe.

1.2 Measurement Functions

1.2.1 The following measurement functions are available in the 2251A Counter.

1.2.1.1 Frequency A. This provides frequency measurement up to 200 MHz using input A.

1.2.1.2 Frequency B. This provides frequency measurement up to 160 MHz using input B.

1.2.1.3 Period A. This provides period measurement from 5 nS using input A.

1.2.1.4 Period B. This provides period measurement from 6.25 nS using input B.

1.2.1.5 Time Interval. This provides Time Interval measurements in two modes; Separate mode, where events at inputs A and B start and stop the measurement, and Common mode, where events at input A both start and stop the measurement.

1.2.1.6 Total A by B. This counts the number of events occurring at input A between events at input B.

Manual Totalize. This counts the number of events between device dependant commands to open and close the counter's gate.

1.2.1.7 Ratio A/B. This measures the ratio of the frequencies applied to inputs A and B.

1.2.1.8 Rise/Fall A. This measures the rise or fall time of a signal at input A, depending on the slope selected.

1.2.1.9 Pulse Width A. This measures the interval between successive rising to falling, or falling to rising edges, depending on the trigger slope conditions specified.

1.2.1.10 Phase A rel B. This measures the phase difference between signals at inputs A and B.

1.2.1.11 Check mode. This mode allows the user to verify the 2251A is operating correctly. Note the capabilities of the Check mode may be extended by the use of special functions.

1.2.1.12 Frequency C. The frequency measurement range of the 2251A is extended to 1.3 GHz with Option 41.

1.2.1.13 Ratio C/B. Frequency ratio measurements up to 1.3 GHz are available when Option 41 is fitted to the 2251A.

1.3 Input Signal Conditioning

1.3.1 The following signal conditioning capabilities are available to both inputs A and B independently.

1.3.1.1 AC or DC coupling

1.3.1.2 1 Megohm or 50 ohm input impedances

1.3.1.3 X1 or X10 input attenuations

1.3.1.4 Positive or negative slope triggering conditions

1.3.1.5 Automatic or user defined input trigger level setting. Note the use of the auto-trigger facility may cause the 2251A input attenuator to change between X10 and X1.

1.3.1.6 Low Pass Filter. A switchable low pass filter is provided that reduces the bandwidth of input A to 50 kHz (nominal).

1.3.2 Additional Capabilities

1.3.2.1 External Arming. Additional qualification of the trigger conditions of a measurement is provided by input D or the VXI trigger bus. Arming conditions are selected by the use of special functions available in the command set.

1.3.2.2 External Frequency Standard Input. The 2251A may be locked to an external reference frequency applied to this input. Selection of the reference frequency is under software control.

1.3.2.3 Math Function. When the math function is active, the 2251A returns values of the form [(Result - X) Y / Z] where Result is a measured value, and X, Y and Z are constants entered by the operator.

1.3.2.4 Averaging Mode. An additional digit of resolution is added to the 2251A output string in this mode. Averages 100 measurements.

1.3.2.5 Special Functions. The measurement and diagnostic capabilities of the 2251A are extended by the special functions available in the command set.

1.4 Options

1.4.1 The following options are available for use with the 2251A.

1.4.1.1 Option 02M: Control Interface Intermediate Language (CIIL) interpreter. This option allows the 2251A to respond to the CIIL command set for use in MATE compatible test systems. Refer to Model 2251A-02M manual, Publication No. 980667.

1.4.1.2 Option 10: External reference multiplier. This option allows the 2251A to be synchronized to any integer sub-multiple of an external 10 MHz reference, e.g. 1, 2, 2.5, 5 MHz.

1.4.1.3 Option 11: This option provides a 0.1 ppm 10 MHz internal reference. The internal reference is also output on the front panel for external use. Option 11 and Option 10 are mutually exclusive.

1.4.1.4 Option 41: Channel C. This option extends the frequency measurement range to 1.3 GHz. Input C has a fixed input impedance of 50 ohms, and a bandwidth of 40 MHz to 1.3 GHz.

1.5 Performance Specifications

This section lists the performance specifications of the 2251A.

1.5.1 Input Characteristics

Inputs A and B available as front panel BNC connectors. Input signal may also be routed to Channel A from any one of the internal analog SUMBUS lines on the VXIbus backplane.

Input A Frequency Range:	DC Coupled: DC to 200 MHz AC Coupled: 10 Hz to 200 MHz
Input B Frequency Range:	DC Coupled: DC to 160 MHz AC Coupled: 10 Hz to 160 MHz
Input Impedance:	1 Megohm or 50 Ohms, selectable
Input Attenuation:	X1 or X10, selectable
Sensitivity (Sinewave) (X1):	25 mV rms to 100 MHz, 0-55°C 50 mV rms to 200 MHz, 0-30°C 60 mV rms to 200 MHz, 30-45°C 70 mV rms to 200 MHz, 45-55°C
Sensitivity (Pulse)(X1):	75 mV pp at 5 ns pulse width
Dynamic Range (X1):	36 dB to 50 MHz (75 mVpp to 5 Vpp) 30 dB to 100 MHz (75 mVpp to 2.5 Vpp) 24 dB to 200 MHz (150 mVpp to 2.5Vpp)
Maximum Input (50 ohm input):	5 V rms
Maximum Input (1 Megohm input):	X1: 260 V (DC+AC rms), DC to 2 kHz, decreasing to 5 Vrms at 100 kHz to 160 MHz. X10: 260 V (DC+AC rms), DC to 20 kHz, decreasing to 50 V rms at 100 kHz to 160 MHz..
Low Pass Filter:	50 kHz (nominal) Input A only
Crosstalk:	<-36 dB between channels, measured at 100 MHz with 50 ohms input impedance selected

Input C (Option 41)

Frequency Range:	40 MHz to 1.3 GHz
Sensitivity (Sinewave):	25 mV rms to 1 GHz 50 mV rms to 1.3 GHz
Dynamic Range:	40 dB to 1 GHz
Input Impedance:	50 ohms (nominal)
VSWR:	< 2:1 at 1GHz
Maximum Operating Input:	1 V rms
Maximum Input Without Damage:	7 V rms

1.5.2 **Trigger Conditions**

Automatic or manual selection in the +5.1 V to -5.1 V range (X1), +51 V to -51 V range (X10)

Trigger Level Range:	X1: ± 5.1 V in 20 mV steps X10: ± 51 V in 200 mV steps
Trigger Level Accuracy:	X1: $\pm 1\%$ of Trigger Level ± 30 mV X10: $\pm 1\%$ of Trigger Level ± 300 mV
Autotrigger Minimum Amplitude:	150 mV pp
Autotrigger Frequency Range:	DC, 50 Hz to 160 MHz (typically to 200MHz)

1.5.3 Measurement Functions

1.5.3.1 Frequency A & B

Range:	Input A: 6×10^{-4} Hz to 200 MHz Input B: 3×10^{-4} Hz to 160 MHz
LSD:	$(1 \text{ ns} / \text{Gate Time}) \times \text{Freq}$
Resolution:	$\pm(2 \times \text{LSD}) \pm 1.4 \times (\text{Trigger Error}^*/\text{Gate Time}) \times \text{Freq}$
Accuracy:	$\pm \text{Resolution} \pm \text{Timebase Error} \times \text{Freq}$

1.5.3.2 Frequency C (Option 41)

Range:	40 MHz to 1.3 GHz
LSD:	$(1 \text{ ns}/\text{Gate Time}) \times \text{Freq}$
Resolution:	$(1 \text{ ns}/\text{Gate Time}) \times \text{Freq}$
Accuracy:	$\pm \text{Resolution} \pm \text{Timebase Error} \times \text{Freq}$

1.5.3.3 Period A

Range:	5 ns to 1.7×10^3 sec
LSD:	$(1 \text{ ns} / \text{Gate Time}) \times \text{Period}$
Resolution:	$\pm (2 \times \text{LSD}) \pm (1.4 \times \text{Trigger Error}^*/\text{Gate Time}) \times \text{Period}$
Accuracy:	$\pm \text{Resolution} \pm \text{Timebase Error} \times \text{Period}$

* Refer to Notes and Definitions

1.5.3.4 Time Interval

Separate Inputs:	Input A start / Input B stop Input B start / Input A stop
Common Inputs:	Input A start / Input A stop
Range:	-2 ns to 1×10^5 sec
Trigger Slopes:	Start, positive or negative Stop, positive or negative
LSD:	1 ns (100 ps with average mode)
Resolution:	\pm LSD \pm 1 ns \pm Start Trigger Error* \pm Stop Trigger Error*
Accuracy:	\pm Resolution \pm (Timebase Error x Time Interval) \pm Trigger Level Setting Error* \pm 2 ns

1.5.3.5 Totalize A By B

Range:	100 MHz; 1 to 10^{12} - 1 events
Pulse Width:	5 ns min at trigger points
Maximum Rate:	10^8 events / sec
Start / Stop:	Input B
LSD:	\pm 1 count
Resolution:	LSD
Accuracy:	LSD

* Refer to Notes/Definitions

Page Changed 3/10/99

1.5.3.6 Frequency Ratio A / B

Range, Inputs A and B:	DC to 100 MHz
LSD:	$(10 \times \text{Ratio}) / (F_A \times \text{Gate Time})$
Resolution:	$\pm \text{LSD} \pm \text{Trigger Error}^* B / \text{Gate Time}$
Accuracy:	$\pm \text{LSD} \pm \text{Trigger Error}^* B / \text{Gate Time}$

1.5.3.7 Frequency Ratio C / B (Only available with Option 41 fitted)

Input C:	40 MHz to 1.3 GHz
Input B:	DC to 100 MHz
LSD:	$(640 \times \text{Ratio}) / (F_C \times \text{Gate Time})$
Resolution:	$\pm \text{LSD} \pm (\text{Trigger Error}^* B) / \text{Gate Time}$
Accuracy:	$\pm \text{LSD} \pm (\text{Trigger Error}^* B) / \text{Gate Time}$

1.5.3.8 Rise / Fall Time

Range:	20 ns to 20 ms
Rise Time:	Start: + slope, 10 % trigger point Stop : + slope, 90 % trigger point
Fall Time:	Start: - slope, 90 % trigger point Stop : - slope, 10 % trigger point
Input Channel:	Input A
Minimum Pulse Height:	500 mV pp
Minimum Pulse Width:	20 ns at signal peaks
LSD displayed:	1 ns (100 ps using averaging mode)
Resolution:	$\pm \text{LSD} \pm 1 \text{ ns} \pm \text{Start Trigger Error}^* \pm \text{Stop Trigger Error}^*$

* Refer to Notes/Definitions

Accuracy: \pm Resolution \pm Trigger Level Timing Error* \pm Trigger Level Setting Error* at 10% Trigger point \pm Trigger Level Setting Error* at 90% Trigger Point \pm 2 ns \pm (Timebase Error x Rise/Fall Time)

1.5.3.9 Pulse Width

Range: 5 ns to 20 ms

Positive Pulse Width: Start: + slope, 50% trigger point
Stop : - slope, 50% trigger point

Negative Pulse Width: Start: - slope, 50% trigger point
Stop : + slope, 50% trigger point

Input Channel: Input A

Minimum Pulse Height: 150 mV pp

LSD: 1 ns (100 ps using averaging mode)

Resolution: \pm LSD \pm 1 ns \pm Start Trigger Error* \pm Stop Trigger Error*

Accuracy: \pm Resolution \pm Trigger Level Timing Error* \pm Trigger Level Setting Error* \pm 2 ns \pm (Timebase Error x Pulse Width)

1.5.3.10 Phase A Rel B

Range: 0.1 to 360⁰

LSD: 0.1⁰ to 1 MHz
1⁰ to 10 MHz
10⁰ to 100 MHz

Resolution: \pm LSD \pm (TI Resolution x 360⁰)/Period A

Accuracy \pm LSD \pm (TI Resolution x 360⁰)/Period A

* Refer to Notes/Definitions

1.5.3.11	Time Interval Delay	
	Time Interval:	Programmable 200 μ s to 800 ms
	Resolution:	25.6 μ s
	Accuracy:	$\pm 50 \mu$ s $\pm 0.1\%$ of reading
1.5.3.12	Peak Signal Measurement	Indicates the maximum, or minimum amplitude or DC value of the measurement signal.
	Frequency Range:	DC, 50 Hz to 20 MHz (useable to 100 MHz)
	Dynamic Range:	50 mV to 51 V pp
	Resolution:	X1:20 mV
	Accuracy (Sinewave):	$\pm 6\%$ of pk-pk voltage ± 50 mV
	Accuracy (DC):	$\pm 1\%$ of reading ± 40 mV
1.5.4	Averaging Mode	May be applied to all functions except totalize. Adds an extra digit of resolution
	Sample Size:	100
1.5.5	Math	May be applied to all counting/timing measurement functions except Trigger Level and Gate Time.
	Result:	$[(\text{Reading} - X) Y] / Z$ where X, Y and Z are constants entered by the operator.
	Constant Range:	$\pm 1 \times 10^{-9}$ to $\pm 1 \times 10^9$

1.5.6 **Gate Time**

Range: 200 μ S to 99.9 S

Resolution: 25.6 μ S

1.5.7 **External Standard Input (Not Available with Option 11)**

Frequency: 10 MHz

Level: Min., 100 mV rms; Max., 10 V rms

Max. Input Level: 400V peak to 500 Hz, decreasing to 10V rms at 30 kHz and above

Impedance: 1 Kilohm (nominal) for signals <1V p-p, decreasing to 500 ohms (nominal) for signals 10V p-p and above. AC coupled.

Note: The external reference multiplier (Option 10) may be used to lock standard frequencies that are subharmonics of 10 MHz.

1.5.8 **External Arming**

Applicability: All functions, except phase, pulse width, rise/fall time, can be armed.

Input Signal: TTL, available from front panel BNC or 8 TTLTRGbus lines, selected under program control.

Arming Mode

- | | |
|---------------------|-----------------|
| 1. Start - Off | Stop - Off |
| 2. Start - Positive | Stop - Off |
| 3. Start - Negative | Stop - Off |
| 4. Start - Positive | Stop - Positive |
| 5. Start - Negative | Stop - Positive |
| 6. Start - Positive | Stop - Negative |
| 7. Start - Negative | Stop - Negative |

NOTE: "OFF" state indicates the counter's internal arm/stop is used.

Minimum Start-Stop Arm Period: 100ns

1.5.9 **Gate Out**

A TTL compatible signal coincident with the measurement gate is accessible to any one of the TTLTRGbus lines. The signal is low while the gate is open.

1.5.10 **Temperature Performance**

Operating Temperature: 0°C to +50°C

Storage Temperature: -40°C to +70°C

1.5.11 **Power Requirements**

Maximum current required on the power supply lines of the P1 and P2 connectors on the backplane:

	+24V	150mA
	-24V	110mA
	+5V	2.5A
	-5.2V	1.6A

1.5.12 **Dimensions** 10.3"H x 1.188"W x 13.775"D
(Not including ejector handles.)

1.5.13 **Weight** Approximately 3 lbs.

1.5.14 **Options**

1.5.14.1 **Option 10 External Frequency Standard Multiplier**

Phase-locked frequency multiplier enabling 1, 2, 5, or 10 MHz to be used as the external standard.

Frequency Input: 1, 2, 5, or 10 MHz \pm 10 ppm

Signal Level: 100 mV rms sinewave min., 10V rms max.

Maximum Input Levels: 400V peak up to 500 Hz, decreasing to 10V rms at 40 kHz and above.

Input Impedance: 1 kilohm (nominal) for signals <1V p-p, decreasing to 500 ohms (nominal) for signals 10V p-p and above. AC

coupled.

1.5.14.2 **Option 11 0.1 ppm Internal Reference**

Frequency	10 MHz
Accuracy	$\pm 1 \times 10^{-8}$
Warm-Up Time	To within 1×10^{-7} in <3 minutes
Temperature Stability	0.05 ppm, -10°C to 55°C
Short Term Stability	3×10^{-11} /second
Aging	≤ 0.1 ppm/year
Internal Reference Output	1V _{rms} nominal into 50Ω TTL/CMOS compatible V _{ohmin} 4.3V at -24 mA V _{olmax} 0.44V at +24mA
Single Sideband (SSB) Phase Noise	-115dBc/Hz @ 10 Hz -145dBc/Hz @ 100 Hz -150dBc/Hz @ 1KHz, 10KHz

NOTE: Options 10 and 11 are mutually exclusive.

1.5.14.3 **Option 41 1.3 GHz Input C**

Factory installed option extending the counter range to 1.3 GHz.

Frequency Range: 40 MHz to 1.3 GHz

(Refer to Sections 1.5.1 and 1.5.3.2 for additional specifications.)

1.6 **Definitions and Notes**

1.6.1 **Trigger Error**

$$\text{Trigger Error} = \frac{\text{SQR} (e_i^2 + e_n^2)}{\text{Input slew rate at trigger point}}$$

where e_i = input amplifier rms noise (typically 150 μ V, 450 μ V max. in a 160 MHz

bandwidth),
and e_n = input signal rms noise in a 160 MHz bandwidth.

1.6.2 **Trigger Level Timing Error**

$$1.6.2.1 \text{ Timing Error} = \pm \left(\frac{\frac{1}{2} \text{ Hysteresis Band}}{|\text{Input Slew Rate at START Trigger point}|} + \frac{\frac{1}{2} \text{ Hysteresis Band}}{|\text{Input Slew Rate at STOP Trigger point}|} \right)$$

where Hysteresis Band is nominally 25 mV.

1.6.3 **Trigger Level Setting Error**

$$1.6.3.1 \text{ Setting Error} = \pm \left(\frac{\text{Trigger Level Accuracy}}{|\text{Input Slew Rate at START Trigger point}|} + \frac{\text{Trigger Level Accuracy}}{|\text{Input Slew Rate at STOP Trigger point}|} \right)$$

1.6.4 **Differential Channel Delay Error**

1.6.4.1 Differential Channel Delay Error is the difference in propagation times between signals applied to inputs A and B of the 2251A.

1.6.5 **Timebase Error**

1.6.5.1 The fractional deviation of the timebase frequency from 10 MHz is due to ageing, temperature, voltage variations, etc. This is determined by the reference frequency used by the 2251A. The default reference frequency is the VXIbus CLK10 signal.

1.6.6 **Resolution & Gate Time**

1.6.6.0.1 Gate time is related to the resolution selected in the Frequency, Period, Ratio, and Check functions as shown below. Gate time is also programmable in increments of 25.6 μ S. The permitted range is 200 μ S to 99.999 S. The default state is 100 ms gate time and 8 digits of resolution. Note the gate time may be extended by:

- one period of the input signal on Frequency B and Ratio A/B
- two periods of the input signal on Frequency A and Period A

Resolution (Number of Selected Digits) in Frequency, Period, Ratio, and Check (See Note 1)	Gate Time
9 + Overflow	10 S
9	1 S
8	100 ms
7	10 ms
6	1 ms
5 See Note 2	1 ms
4 " "	1 ms
3 " "	1 ms

When setting the resolution by programming the number of digits, use the following formula to determine the value of the LSD (Least Significant Digit):

$LSD = F \times 10^{-D}$ where F = Frequency and D = Number of digits rounded up to the next decade.

NOTE 1:

The most significant digit is permitted to exceed the resolution by 1 digit providing a 10% overrange. This precludes unnecessary shifting of digits.

NOTE 2:

Measurements of frequency, period, ratio and check are averaged when these gate times are set.

1.6.6.1 The resolution of phase and totalize is determined by the input signal.

1.6.6.2 Time interval, rise/fall time, and pulse width measurements have the resolution determined by both the input signal and the resolution set.

1.6.6.3 Resolution is programmable from three to nine digits. But the minimum LSD the counter will achieve is 1 ns, regardless of programmed gate time or resolution in time interval mode. Exception is if measured time interval or period is ≥ 10 seconds.

1.7 Safety

Refer to the **“FOR YOUR SAFETY”** page preceding the Table of Contents. Follow all **NOTES, CAUTIONS** and **WARNINGS** to ensure personal safety and prevent damage to the instruments.

1.8 Product Support

Racal Instruments has a complete Service and Parts Department. If you need technical assistance or should it be necessary to return your product for servicing, call 1-800-722-3262 or call 714-859-8999 and ask for Customer Support. You may also contact Customer Support via E-Mail at:

customer_service@rdii.com

If parts are required to repair the product at your facility, call 1-800-722-3262 and ask for the Parts Department.

When sending your instrument in for repair, complete the form in the back of this manual.

2.1 Introduction

2.1.1 This section describes the unpacking and inspection, reshipment, and installation requirements of the 2251A.

2.2 Unpacking and Inspection

2.2.1 Before unpacking the counter, check the exterior of the shipping carton for any signs of damage. All irregularities should be noted on the shipping bill. Remove the instrument from its carton, preserving the factory packaging as much as possible. Inspect the counter for any defect or damage. Notify the carrier immediately if any damage is apparent. Have a qualified person check the instrument for safety before use.

2.3 Reshipment Instructions

2.3.1 Use the original packing if it is necessary to return the counter to Racal Instruments for calibration or servicing. The original shipping carton and the instruments plastic foam will provide the necessary support for safe reshipment. If the original packing is unavailable, wrap the counter in plastic sheeting and use plastic spray foam to surround and protect the instrument. Reship in either the original or a new, sturdy shipping carton.

2.4 Interrupt Level and Logical Address Setting

2.4.1 The Interrupt Level and Logical Address of the 2251A are not software controllable. Carry out the following procedure if it is necessary to change either the Logical Address or the Interrupt Level.

2.4.2 To set the interrupt level of the 2251A, set switch S1 to the binary equivalent of the interrupt level selected. Interrupt levels between 0 and 7 inclusive are permitted. The OFF switch positions on S1 correspond to binary 1. The 2251A is shipped from the factory with the interrupt level set to 02.

2.4.3 To set the logical address of the 2251A, set switch S2 to the binary equivalent of the logical address selected. Logical addresses between 1 and 254 (FF_{HEX}) are permitted. The OFF switch positions on S2 correspond to binary 1. The 2251A is shipped from the factory with the logical address set to 03. Refer to **Figure 2-1** for an illustration of the location of the switches and their default settings.

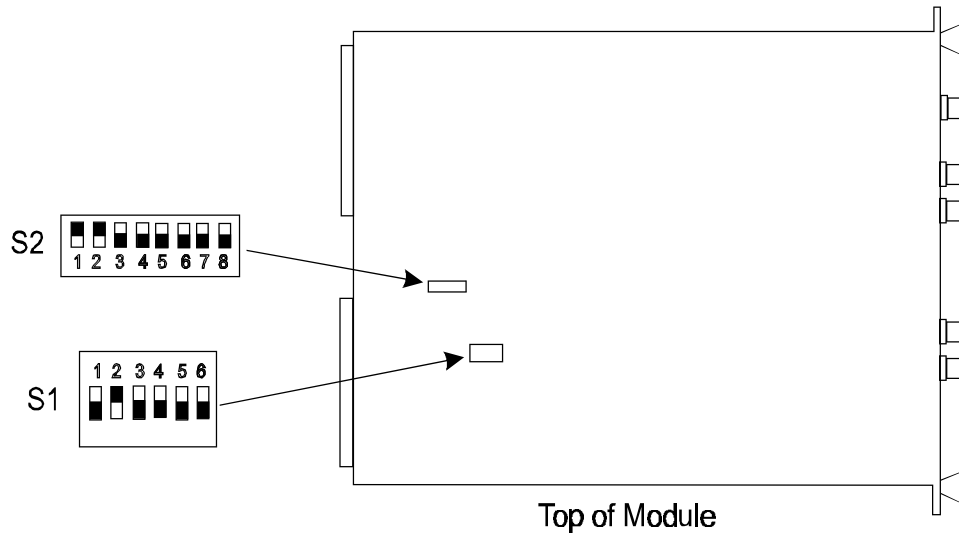

Figure 2-1 Location of Switches

2.5 Installation

- 2.5.1 Before attempting installation of the 2251A, carry out a visual inspection of the counter. Pay particular attention to connectors P1 and P2 on the rear of the counter, and ensure there are no bent, damaged or missing pins. Repair any damage to the counter before proceeding.
- 2.5.2 To install the 2251A in a C size, VXI mainframe, ensure the 2251A has rear connector P1 oriented to mate with the corresponding connector on the mainframe backplane. Align the 2251A with the guides for the slot selected, and slide the counter into the mainframe. Push the counter home to connect the 2251A to the mainframe. Secure the 2251A to the mainframe with the captive screws provided at the top and bottom edges of the counter.
- 2.5.2.1 Poor mechanical alignment of 2251A rear connectors P1 and P2 may require the counter be reseated in the VXI mainframe. Do NOT use undue force to seat the counter.
- 2.5.3 Power-up the mainframe. Ensure the SYSFAIL LED on the 2251A front panel lights and extinguishes after a few seconds to show the counter has passed its power-up self test. The 2251A is now ready for use.
- 2.5.4 To remove the 2251A from the VXI mainframe, power-down the mainframe, and release the captive screws that secure the 2251A to the mainframe. Use the plastic levers provided on the top and bottom edges to eject the 2251A from the mainframe. Pull the counter along the guides provided and out of the mainframe.

3.1 VXIbus Control

3.1.1 Introduction

This subsection provides programming information for the 2251A using the VXIbus interface. The VXIbus interface permits control of all the counter's functions.

3.2 VXIbus Logical Address and Interrupt Level Assignment

- 3.2.1 Refer to **Section 2.4** of this manual for instructions on setting the Logical Address and Interrupt Level. Although there are a variety of Resource Managers and their display formats vary, it is recommended that the user verify the Logical Address and Interrupt Level by viewing the configuration returned after start-up.

3.3 2251A Home State

3.3.1 The 2251A Home State is the default configuration the 2251A will adopt on powering-up. Refer to **Table 3.1** for details of the 2251A home state.

Table 3.1 - 2251A Home State

2251A FEATURE	DEFAULT SETTING
Logical Address	03 (as shipped from the factory)
Interrupt Level	02 (as shipped from the factory)
Trigger Levels	Manual, Set to 0.00 V
Input Coupling	AC, Inputs A and B
Measurement Mode	Frequency A
Time Interval Delay	200 μ s, Disabled
Gate Time	100 ms/8 Digits
Input Impedance	1 Megohm, Inputs A and B
Input Attenuation	X1, Inputs A and B
Math Constants	X=0, Y=1, Z=1, Math Disabled
Input Mode	Separate Inputs
Input A Low Pass Filter	Off
Input A Trigger Slope	Positive
Input B Trigger Slope	Positive
Measurement Hold	Continuous
RQS Assertion	Off
Input Source	Front Panel
Reference	Internal
Gate Output	Disabled
External Arm	Front Panel, Disabled

3.4 Functional Check

3.4.1 Introduction

The following procedure verifies that the 2251A can accept, process, and transmit device-dependent messages over the VXIbus. (The Logical Address is set to 03 when shipped from the factory, and will be used in all examples.)

The following sequence will use the command WSWrt. This is a short way of indicating the following device-dependent commands are transmitted to the 2251A using the Word Serial Write protocol of the VXIbus Specification (to which the counter conforms). The command WSRd indicates that data is to be read from the 2251A using the VXIbus specified Word Serial Read protocol.

3.4.2 VXIbus Communication Check

Perform the following procedure:

- a. Power-on the counter.
- b. Test as shown below:

Action	Command
Send the IEEE-488.2 command "*TST?"	WSWrt 03 "*TST?" <LF>

- c. Verify the TRIG A LED and the GATE LED are flickering.
- d. Read the data in the output buffer by performing the following:

Action	Command	Self Test Data
Read Data	WSRd 03	"0" = Pass "1" = Fail

3.4.3 RQS, Status Byte and Interrupt Check

Action	Commands
<p>Set the 2251A to transmit the RQS when an error is detected, and force the generation of Command Error bit of the ESR by sending erroneous device-dependent command "XXX" <LF></p> <p>Verify that Interrupt Line 02 is asserted. (Line 02 is the default level set at the factory, and will be used in all examples).</p>	<p>WSWrT 03 "*ESE 32" <LF> WSWrT 03 "*SRE 32" <LF> WSWrT 03 "XXX" <LF></p> <p>WSWrT 03 "*STB?" <LF> Verify the value of the Status Byte query is 96. Refer to Sections 3.14 - 3.16 for more information about the Status Byte and Error Reporting.</p>

3.5 Output Message Format

3.5.1 The output strings generated by the 2251A are 21 bytes long. They are of the form:

<aa> <±><nnnnnnnnnn><E><± >< m><cr>< f>

where:

<aa> is a 2 byte header that describes the measurement mode the 2251A is in, or the type of data recalled. Refer to **Tables 3.1** and **3.2** for the headers the 2251A can generate.

<±> describes the polarity of the measurement result.

<nnnnnnnnnn> is numerical data. n=0 to 9 or a decimal place (.). Leading zeros will be added to ensure that 11 bytes are output in this part of the output string, if required. The decimal point may float to any position in the field except the first.

<E> is an exponent indicator.

<mm> is the exponent that <E> is raised to. m= 0, 3, 6 or 9.

<cr><lf> is an ASCII terminator

NOTE

The two byte, character header, <aa>, may be removed by the use of Special Function 81. Two spaces are transmitted.

The following table describes the headers for each measurement value which is output.

Table 3.2 - 2251A Measurement Mode Output Strings

MEASUREMENT MODE	OUTPUT STRING HEADER
Frequency A	FA
Frequency B	FB
Frequency C (See Note)	FC
Period A	PA
Time Interval A - B	TI
Totalize A by B	TA
Ratio A / B	RA
Ratio C / B (See Note)	RC
Rise Time A	RT
Fall Time A	FT
Positive Pulse Width A	PW
Negative Pulse Width A	NW
Phase A Rel B	PH

NOTE

Option 41 must be fitted for the 2251A to be able to generate FC or RC.

Table 3.3 - 2251A Recalled Data Output Strings

RECALLED DATA	OUTPUT STRING HEADER
Unit Type	UT
Resolution	RS
Trigger Level A	LA
Trigger Level B	LB
Math Constant X	MX
Math Constant Y	MY
Math Constant Z	MZ
Delay Time	DT
Special Function	SF
Master Software Issue	MS
VXI Processor Software Issue	GS
Gate Time	GT

Note: LA and LB will refer to the positive and negative peak amplitude of the signal when Special Functions 51 and 52, respectively, are enabled.

3.6 Input Commands

3.6.1 Introduction

The 2251A responds to device-dependent commands in a "deferred" mode. This means the 2251A continues to accept commands until a terminating character or message is received; then, the entire string will be executed. To insure that the commands have been processed a "*OPC?" command can be given and then the response of "1" read back will indicate that the 2251A has acted on all received commands.

3.6.2 Device-Dependent Commands

The Device-Dependent commands for the 2251A are listed below, and grouped by category in the following tables.

Table 3-5	Instrument Preset Conditions
Table 3-6	Instrument Preset Code
Table 3-7	Numerical Input Format
Table 3-8	Measurement Function Codes
Table 3-9	Numerical Input Ranges
Table 3-10	Resolution Control Selection
Table 3-11	Input Control Codes
Table 3-12	Measurement Control Codes
Table 3-13	Store and Recall Codes
Table 3-14	Special Function Codes
Table 3-15	Using the Special Function
Table 3-16	IEEE-488.2 Command Codes
Table 3-17	STA Related "Q" Codes
Table 3-18	2251A STA Response Description
Table 3-19	2251A STA Error Code Set
Table 3-20	Alphabetical List of Command Codes

Device-dependent commands are executed sequentially beginning with the first one sent and ending with the last.

If more than one command is to be sent, no delimiters are required. If necessary, commas, spaces, and semicolons may be included in the command strings for clarification without affecting counter operation.

3.6.3 Command String Terminators

Each command string must be followed by an end-of-string terminating group. **Table 3.4** shows the valid terminator groups.

Table 3.4 - Permitted Terminators

1	2	3	4	5	6
LF	LF End Bit	CR End Bit	CR LF	CR LF End Bit	Last Character End Bit
Where LF = Line feed, CR = Carriage Return End Bit in VXIbus Data Low Register is Set					

3.6.4 Instrument Preset Device (IP)

The Instrument Preset (IP) device dependent command aborts any measurement in progress, clears all buffers and registers, and returns all functions to the default condition.

Table 3.5 provides the instrument preset condition for the 2251A following the device-dependent command (IP).

Table 3.5 - Instrument Preset Conditions

2251A DEFAULT FUNCTION	COMMANDS
Frequency A	FA
Trigger Levels Manual, Set to 0.00 V	AMN, BMN
Input Coupling AC, Inputs A and B	AAC, BAC
Inputs A and B Impedance, 1 M Ω	AHI, BHI
Inputs A and B Input Attenuation, X1	AAD, BAD
Input A Low Pass Filter Off	AFD
Input A and B Trigger Slope, Positive	APS, BPS
Input Mode, A and B Separate	BCS
Math Constants X=0, Y=1, Z=1, Math Disabled	MD
Continuous Measurement Mode	T0
SRQ Assertion Disabled	Q0
Time Interval Delay 200 μ s, Disabled	DD
Source, Front Panel	A0
Reference CLK10	B0
Gate Output Disabled	D8
External Arm, Front Panel	R8
Arm Internal	S10

Table 3.5 - Instrument Preset Conditions

2251A DEFAULT FUNCTION	COMMANDS
Channels A and B Default	S20
Continuous Auto Trigger (If Auto-Trig Enabled)	S30
Recall Trigger Level (Not peak amplitude)	S50
Totalize A by B (If in TA function)	S60
Measurers Internal 10MHz Reference (If in CK)	S70
Two Character Header Enabled	S80

Table 3.6 - Instrument Preset Code

Function	Code
Sets counter functions and settings to Home State	IP

NOTE

Some of the device-dependent commands in the following tables require additional numerical input data. Such numerical input follows its command and is indicated by an asterisk (*) in the tabulations. Numerical Input format is described in **Table 3.7**. Home state commands are underlined in all of the following tables.

Table 3.7 - Numerical Input Format

Byte No.	Interpretation	Permitted ASCII Characters
1	Sign of mantissa	+ or -
2	Most significant digit	0 to 9 or .
3		
4		
5		
6		
7		
8		
9		
10		
11	Least significant digit	
12	Exponent indicator	E or e
13	Exponent sign/space	+ or - or space
14	More significant digit	0 to 9
15	Less significant digit	0 to 9

- NOTES:**
1. Spaces, nulls or zeros occurring before byte 1 are ignored by the counter.
 2. Byte 1 may be omitted and a positive mantissa assumed.
 3. Bytes 2 to 11 may have up to nine digits and a decimal point. The decimal point is not essential. After entry of nine digits (without a decimal point), additional digits are ignored and a programming error is generated. Excess digits that are truncated will still increase the power-of-ten stored. Also, if fewer than nine digits are needed, unused bytes may be omitted.
 4. Spaces or nulls entered between bytes 11 and 12 are ignored by the counter.
 5. Bytes 12 to 15 (exponent group) may be omitted. Also, byte 13 may be omitted or transmitted as a space (a positive exponent should be assumed in either instance).

3.7 Selecting the Measurement Function

3.7.1 Each measurement function is selected by a two-character code. **Table 3.8** presents the measurement function codes for the 2251A.

Table 3.8 - Measurement Function Codes

Function	Code
Frequency A	FA
Frequency B	FB
Frequency C	FC
Period A	PA
Time Interval A B	TI
Totalize A by B	TA
Ratio A/B	RA
Ratio C/B	RC
Rise Time A	RT
Fall Time A	FT
Positive Pulse Width A	PW
Negative Pulse Width A	NW
Phase A Rel B	PH
Check	CK

NOTE

Option 41 must be installed in the 2251A for FC and RC to be accepted as valid commands.

3.8 Numerical Input Data

3.8.1 **Table 3.9** provides the various numerical input ranges for each function and feature for the 2251A.

Table 3.9- Numerical Input Ranges

Function	Command Code	Numerical Limits	
		Low	High
Set Resolution (Number of Digits)	SRS	3	10
Trigger Level (X1)	SLA, SLB	-5.1	+5.1
Trigger Level (X10)	SLA, SLB	-51	+51
Math Constant	SMX, SMY, SMZ	$\geq 1 \times 10^{-9}$ $\geq -1 \times 10^{10}$	$< 1 \times 10^{10}$ $\leq -1 \times 10^{-9}$
Delay/Gate Time	SDT/SGT	$\geq 200 \mu s$	$\leq 99.999 s$
Set-up Memory (RAM)	SM/RM	≥ 0	≤ 9

- NOTES:**
1. Entered numbers will be rounded up before storage as follows:
 - a. Trigger Level X1 to next multiple of 20 mV
 - b. Trigger Level X10 to next multiple of 200 mV
 - c. Delay/gate time to next multiple of 25.6 μs
 2. Resolution entries are rounded down to the next integer. Refer to **Table 3.10** for resolution numbers and related gate times.
 3. Math constant Z can be set to 0. However, an error message will result if the Math function is enabled with this value set.
 4. Set-up Memory (RAM) commands require a single-digit suffix ranging from 0 to 9.

3.9 Resolution Control Selection

- 3.9.1 The 2251A provides a selection of resolution for frequency and time interval. In frequency, the resolution or number of digits displayed is related to the gate time. Refer to Section 1, Specifications for a description of the relationship between resolution, LSD, and accuracy. In Time Interval, all measurements result in 1 nanosecond LSD. However, the least significant digits can be truncated for display using the SRS command.
- 3.9.2 **Table 3.10** provides the 2251A resolution control selection.

Table 3.10 - Resolution Control Selection

Command Code To Select Resolution Number of Digits	Number of Selected, Digits in Frequency, Period Ratio, and Check	Gate Time
SRS 10	10	10 s
SRS 9	9	1 s
SRS 8	8	100 ms
SRS 7	7	10 ms
SRS 6	6	1 ms
SRS 5	5	1 ms
SRS 4	4	1 ms
SRS 3	3	1 ms

- NOTES:**
1. The most significant digit is permitted to exceed the resolution by 1 digit providing a 10% overrange. This precludes unnecessary shifting of digits.
 2. Measurements of frequency, period, ratio, and check are averaged when these gate times are set if period of signal is less than programmed gate time.

3.10 Signal Conditioning Parameters

3.10.1 The following table lists the command codes for setting up the signal conditioning parameters on Inputs A and B.

Table 3.11 - Input Control Codes

Function	Code
FILTER <u>D</u> isable/Enable (Input A)	<u>A</u> FD/ <u>A</u> FE
COM A <u>D</u> isable/Enable	<u>B</u> CS/ <u>B</u> CC
DC/ <u>A</u> C Coupling A	<u>A</u> DC/ <u>A</u> AC
DC/ <u>A</u> C Coupling B	<u>B</u> DC/ <u>B</u> AC
<u>1</u> M Ω /50 Ω Impedance A	<u>A</u> HI/ <u>A</u> LI
<u>1</u> M Ω /50 Ω Impedance B	<u>B</u> HI/ <u>B</u> LI
Slope A <u>P</u> os/Neg	<u>A</u> PS/ <u>A</u> NS
Slope B <u>P</u> os/Neg	<u>B</u> PS/ <u>B</u> NS
X10 Attenuator A <u>D</u> isable/Enable	<u>A</u> AD/ <u>A</u> AE
X10 Attenuator B <u>D</u> isable/Enable	<u>B</u> AD/ <u>B</u> AE
<u>M</u> anual/AUTO-TRIG A	<u>A</u> MN/ <u>A</u> AU
<u>M</u> anual/AUTO-TRIG B	<u>B</u> MN/ <u>B</u> AU

3.11 Measurement Control Codes

3.11.1 The 2251A offers a number of features which assist in setting up measurement features.

Table 3.12 - Measurement Control Codes

Function	Code
Enables <u>Continuous</u> measurement mode	<u>T0</u> (See NOTE 1)
Enables Single (One-Shot) measurement mode	T1 (See NOTE 2)
Trigger a measurement (T1 mode) or start a Totalize measurement	T2 (See NOTE 3)
Stop Totalize Measurement	T3 (See NOTE 3)
Read current value of totalize measurement in progress	RF (See NOTE 4)
Math function <u>Disable/Enable</u>	<u>MD/ME</u>
Stop Delay <u>Disable/Enable</u>	<u>DD/DE</u>
Average a sample of 100 <u>Disable/Enable</u>	<u>NA/AE</u>
Special function <u>Disable/Enable</u>	<u>SFD/SFE</u>
Reset measurement	RE

- NOTES:**
1. In continuous measurement mode, the output buffer is updated at the end of each gate period. If the buffer is being read when the gate period ends, updating is delayed until reading is complete.
 2. In single-measurement mode, the output buffer is cleared every time a T2 command is received.
 3. In making manual totalize measurements, T2 and T3 commands are used with the TA command with Special Function 61 enabled. In this mode, the reading executed in successive totalize periods are cumulative; (the RE command resets the count to 0 when required).
 4. The RF command is sent during manual totalize each time a reading is required, before the T2 command has been sent to stop the totalize measurement.

3.12 Store and Recall Codes

3.12.1 The 2251A permits the user to store and recall information about the setup and its parameters.

Table 3.13 - Store and Recall Codes

Function	Code
Recall unit type	RUT
Recall master software issue	RMS
Recall GPIB software issue	RGS
Store/Recall Display resolution (Defaults to 8)	SRS/RRS
Store/Recall trigger level A (Defaults to 0V)	SLA/RLA (See NOTE 1)
Store/Recall trigger level B (Defaults to 0V)	SLB/RLB (See NOTE 1)
Store/Recall math constant X (Defaults to 0)	SMX/RMX
Store/Recall math constant Y (Defaults to 1)	SMY/RMY
Store/Recall math constant Z (Defaults to 1)	SMZ/RMZ
Store/Recall arming delay time (Defaults to 200 μ s)	SDT/RDT
Store/Recall gate time (Defaults to 100 ms)	SGT/RGT
Store/Recall memory (0 through 9)	SM/RM (See NOTE 2)
Store/Recall special function (Defaults to all SFs off)	S/RSF

- NOTES:**
1. Recalled values do not cause the "Reading Ready" bit in the status byte to be set nor the SRQ to be asserted, even if masked.
 2. Storing a trigger level value is only allowed if Manual Trigger is enabled (AMN, BMN). Attempting to store a trigger level when auto-trigger (AAU, BAU) is enabled will result in an error.

- NOTES:**
3. The manual trigger level is automatically scaled by a factor of 10 when the X10 attenuator key is toggled in or out-of-circuit. The correct input attenuation must be selected before storing or recalling the trigger level.
 4. The SM and RM codes are used to store and recall complete measurement setups into RAM. Both SM and RM must be followed by a measurement setup number from 0 to 9.

3.13 Special Functions

- 3.13.1 The 2251A allows for extended capabilities by the use of special functions. Special functions are organized by decades, one for each of the nine mantissa output string digits. One special function from each decade may be entered into the special function register, but only the second digit of the special function number is stored. The first digit of the special function number is indicated by the position in the output string. The default state has 0's entered in all positions. The special function output string is generated in response to the RSF command code.
- 3.13.2 Special function numbers must be entered into memory before special functions can be enabled. When a number is stored, it overwrites the number stored in the same decade. Therefore, to remove a number from its register, another number from the same decade must be stored.
- 3.13.3 The power-on home state for special functions is that none are stored, that is, all are at the default for the decade (10, 20....80)

Table 3.14 - Special Function Codes

SF Number	Function	
Arming	Start	Stop
<u>10</u>	Internal	Internal
11	External+ve	Internal
12	External-ve	Internal
15	External+ve	External+ve
16	External+ve	External-ve
17	External-ve	External+ve
18	External-ve	External+ve
<u>20</u>	Normal Operation	
21	Inputs A and B interchanged. Permits PERIOD B and TI B to A measurements, for example. See NOTE following.	
<u>30</u>	Continuous Auto-trigger measurement	
31	Single-shot auto-trigger measurement	
<u>50</u>	Selects Mean Amplitude Measurement Mode	
51	Selects Positive Peak Amplitude Mode	
52	Selects Negative Peak Amplitude Mode	
<u>60</u>	Totalize A by B (When in TA)	
61	Manual Totalize (When in TA)	
<u>70</u>	Basic 10 MHz Check	
72	Start TEC short continuous calibration; display shows TEC count (Must enable CK mode)	
73	Start TEC long continuous calibration; display shows TEC count (Must enable CK mode)	
74	Stop TEC short calibration (Must enable CK mode)	
75	Stop TEC long calibration (Must enable CK mode)	
76	Input A and B DAC Check (Must enable CK mode)	

Table 3.14 - Special Function Codes (Continued)

SF Number	Function	
Arming	Start	Stop
77	Input A relay check (Must enable CK mode)	
78	Input B relay check (Must enable CK mode)	
<u>80</u>	Two Character header enabled	
81	Two character header disabled	

Table 3.15 - Using The Special Function

Function	Code
Special functions <u>Disabled/Enabled</u> Store special function nn	<u>SFD/SFE</u> Snn

- NOTES:**
1. Storing a special function when special functions are enabled immediately enables that special function.
 2. In Special Function 21, Frequency B is specified to 160 MHz only; Period B is specified to 6.25 ns only; Totalize B by A operates for one complete cycle of Input A.
 3. Special Functions 77 and 78 require connection of a 10 MHz internal standard to Input A or B. Refer to **Section 4.1.5.1** for a description of required signals.

3.13.4 Recalling the special functions stored results in an 8-digit output with the format SF000nnnnnnnnE+00 where "n" refers to the stored decade.

3.14 2251A Supported IEEE-488.2 Commands

Table 3.16 - IEEE-488.2 Command Codes

Function	Code
Identification Query	*IDN?
Reset Command	*RST
Internal Self-Test Query	*TST?
Clear Status Command	*CLS
Set Standard Event Status Enable Register Value	*ESE <NRf>
Standard Event Status Enable Register Query	*ESE?
Standard Event Status Register Query	*ESR?
Set Service Request Enable Register Value	*SRE<NRf>
Service Request Enable Register Query	*SRE?
Read Status Byte Query	*STB?
Operation Complete Command	*OPC
Operation Complete Query	*OPC?
Wait-to-Continue Command	*WAI
Trigger Command	*TRG
Option Identification	*OPT?
Device Dependent Status Byte (old 2251 Status Byte)	*STA?

NOTE: <NRf> is a numerical input in the range of 0 to 255. Complies with IEEE-488.2 **Section 7.7.2** for the accepted input formatting.

- 3.14.1 ***IDN?** Respond with the 2251A's Identify string. e.g.
RACAL INSTRUMENTS, 2251A, 0, 19.1
- 3.14.2 ***RST** Preset the 2251A to a know state. See **Table 3.5** - Instrument Preset Conditions
- 3.14.3 ***TST?** Command the 2251A to do an Internal Self Test. The response will be a 0 if the test passed and a 1 if the test failed.
- 3.14.4 ***CLS** Clears the Event Registers summarized in the Status Byte and all queues except the output.
- 3.14.5 ***ESE <NRf>** Program the mask for the Standard Event Status Register. <NRf> is in the range of 0 to 255. See **Figure 3-1** for the bit value definition.

- 3.14.6 ***ESE?** Query the Standard Event Enable Register. This mask register is programmed via the *ESE <NRf> command.
- 3.14.7 ***ESR?** Query the Standard Event Status Register. The response will be a base 10 number from 0 to 255 (see **Figure 3-1**). The Active bits are: Power On, User Request, Command Error, Execution Error, Query Error, and Operation Complete.
- 3.14.8 ***SRE <NRf>** Program the mask for the Status Request Enable Register. <NRf> is in the range of 0 to 255. See **Figure 3-1** for the bit value definition.
- 3.14.9 ***STB?** Query the Status Byte Register. The response will be a base 10 number from 0 to 255 (see **Figure 3-1**). The Active Bits are: MSS/RQS, ESB, MAV, and DDSB. The MSS/RQS, ESB, and DDSB bits are active only if their corresponding masks are enabled.
- 3.14.10 ***OPC** This command will respond with the Operation Complete Bit in the ESR being Set after the 2251A has completed all pending commands. Reading the ESR will clear the OPC bit.
- 3.14.11 ***OPC?** This command will respond with a 1 after the 2251A has completed all pending commands.
- 3.14.12 ***WAI** Wait for the 2251A to complete all pending commands.
- 3.14.13 ***TRG** Trigger the 2251A to start a measurement. Used with the T1 Command and the same as sending a T2 command.
- 3.14.14 ***OPT?** Report the Channel C option status. The response is 0 if not installed and 1 if installed.
- 3.14.15 ***STA?** Return the 2251 (old status) Status byte. See **Table 3.18** for the bit description.
- 3.14.16 When commanded by a GPIB slot 0; The 2251A responds to the GPIB SDC (Selected Device Clear) and DCL (Device Clear) commands by clearing its input and output buffers. This aborts any command string processing taking place, and any pending commands are lost.

3.15 2251A IEEE-488.2 Status Reporting Structure Requirements

The IEEE-488.2 Specification requires the implementation of the Status Data Structures. These are shown in **Figure 3-1** which is a replica of **Figure 11-8** in the IEEE-488.2 1987 Specification.

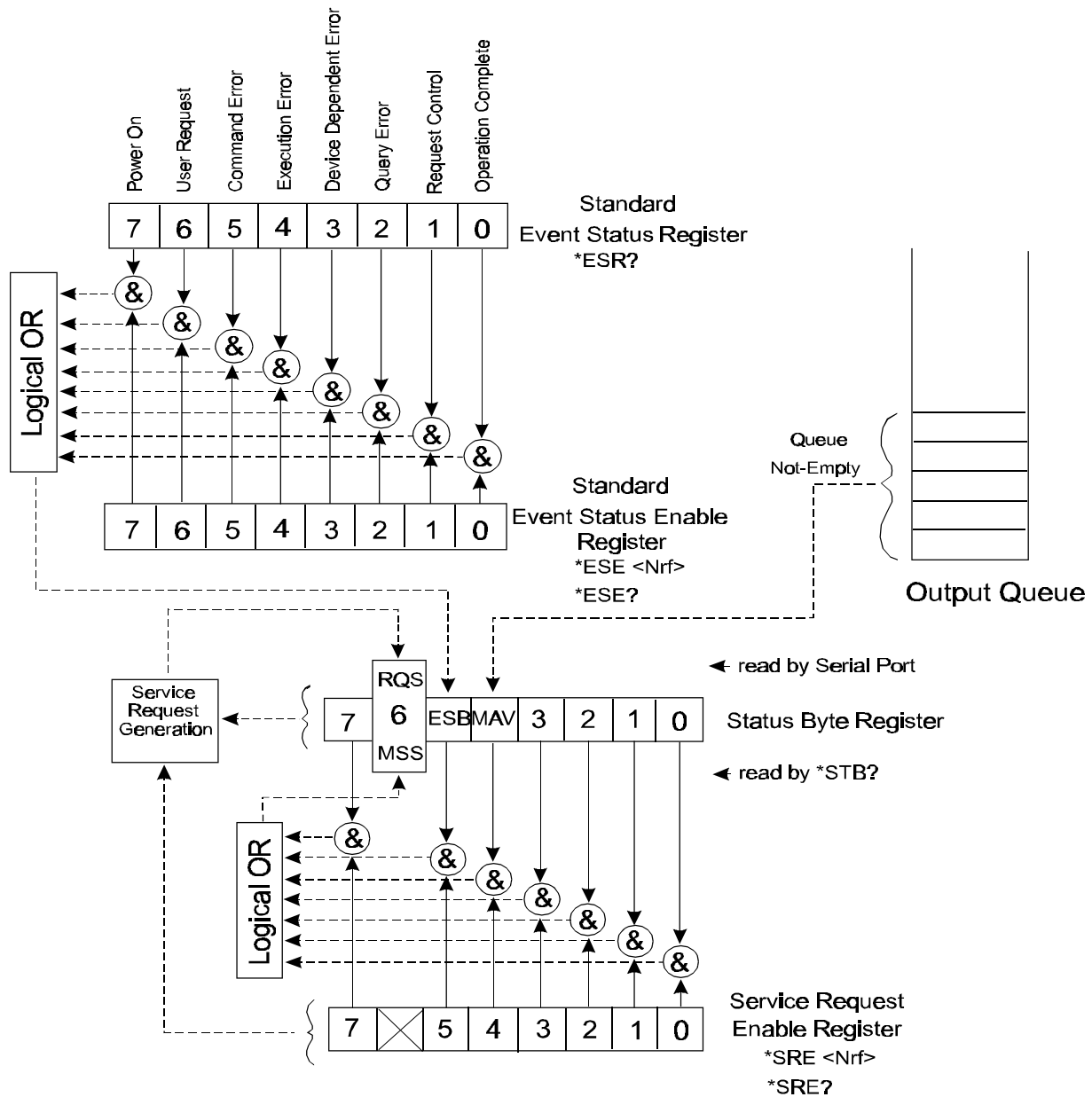

Figure 3-1 IEEE-488.2 Status Reporting Model

NOTE: Bit 0 of the Status Byte is asserted via Bit 7 (SRQ Bit) of the Device Dependent Status Byte. See **Section 3-16** below.

3.16 Device Dependent Status Bit (DDSB)

3.16.1 This section describes the 2251A Device Dependent Status command “*STA?” and the conditions that will set the DDSB (bit 0 of the Status Byte).

3.16.2 2251A SRQ Assertion

The conditions for the 2251A to assert the DDSB (which would have been the SRQ bit of the old 2251 status byte) are as follows:

- a) Measurement cycle completed
- b) Frequency standard changed to external
- c) Error condition detected
- d) Any combination of the above

NOTE

DDSB assertion is qualified by the use of the command codes Q0 to Q7.

Table 3.17 - STA Related “Q” Codes

Function	Code
DDSB generation inhibited	Q0
DDSB generation upon error detected	Q1
DDSB generation for measurement ready	Q2
DDSB generation for measurement ready or error detected	Q3
DDSB generation for frequency standard change	Q4
DDSB generation for frequency standard change or error detection	Q5
DDSB generation for measurement ready or frequency standard change	Q6
DDSB generation for measurement ready, frequency standard change, or error detected	Q7

- NOTES:**
- 1. An DDSB is not asserted for recalled data.
 - 2. Frequency Standard change will cause the DDSB to be set if reference is changed from internal to external or external to internal.

3.16.3 2251A Status Byte

The 2251A status byte is obtained in response to the *STA? command. The byte is eight bits wide, and the individual bits are interpreted as shown in **Table 3.18**.

Table 3.18 - 2251A STA Response Description

BIT	EXPLANATION
1 (lsb), 2 and 3	Error number (1 to 5) in binary
2	
3	
4	1 = External frequency standard
5	1 = Reading ready
6	1 = Error condition
7	1 = Service requested (SRQ)
8 (msb)	1 = Gate open

3.17 Error Messages

3.17.1 This section lists the errors the 2251A can generate. Refer to **Table 3.19** for these messages, and an explanation of the cause of each error. Errors 50 to 58 may only be generated if the appropriate special function is enabled and the Check function is selected.

Table 3.19 - 2251A STA Error Code Set

ERROR	EXPLANATION
01	Signals of different frequencies used in phase measurement mode
02	Measurement result too large
03	Internal counter overflow
04	Numerical entry error
05	GPIB syntax error
50	Check mode error
51	X1/X10 Input A relay check failure
52	50 Ω/1MΩ Input A relay check failure
53	AC/DC coupling Input A relay check failure
54	Input A low pass filter relay check failure
55	COM A relay check failure
56	X1/X10 Input B relay check failure
57	50 Ω/1MΩ Input B relay check failure
58	AC/DC coupling Input B relay check failure

- NOTES:**
1. When Error 05, GPIB Syntax Entry Error occurs, the erroneous command string will be correctly executed up to the error; the rest will be handshaken, but not executed. Receipt of the next valid command clears the error.
 2. Errors 50 to 58 are only possible when the Check function is programmed, and are read via Word Serial Protocol. They do not cause generation of the SRQ. The error will be reported in engineering format, e.g., Error 51 is reported as CK+0000000051.e+00.

Table 3.20 - Alphabetical List of 2251A Command Codes

CODE	RESPONSE
Note: Underlines indicate power-up default conditions.	
<u>A0</u>	Selects front panel Input A
A1	Selects SUMBUS Input A signal source
A2	Connects timebase reference to Input A
<u>AAC</u>	Selects Input A AC coupling
<u>AAD</u>	Disables Input A X10 Attenuator
AAE	Enables Input A X10 Attenuator
AAU	Selects Input A auto-trigger Mode
ADC	Selects Input A DC coupling
AE	Enables averaging mode, 100 samples
<u>AFD</u>	Disables Input A low pass filter
AFE	Enables Input A filter
<u>AHI</u>	Sets Input A input impedance to 1 Megohm
ALI	Sets Input A input impedance to 50 ohms
<u>AMN</u>	Selects Input A manual trigger mode
ANS	Sets Input A trigger to negative slope
<u>APS</u>	Sets Input A trigger to positive slope
B0	Selects 10 MHz signal from backplane as reference frequency
B1	Selects EXT STD. INPUT as reference frequency
<u>BAC</u>	Selects Input B AC coupling
<u>BAD</u>	Disables Input B X10 attenuator
BAE	Enables Input B X10 attenuator
BAU	Selects Input B auto-trigger mode attenuator
BCC	Selects Inputs A and B "common" mode
<u>BCS</u>	Selects Inputs A and B "separate" mode

Table 3.20 - Alphabetical List of 2251A Command Codes (continued)

CODE	RESPONSE
BDC	Selects Input B DC coupling
<u>BHI</u>	Sets Input B input impedance to 1 Megohm
BLI	Sets Input B input impedance to 50 ohms
<u>BMN</u>	Selects Input B manual trigger mode
BNS	Sets Input B trigger to negative slope
<u>BPS</u>	Sets Input B trigger to positive slope
*CLS	Clear Status Registers command
CK	Selects CHECK mode
D0	Enable Gate out signal on backplane connector P2 A 23 (TTLTRG0)
D1	Enable Gate out signal on backplane connector P2 C 23 (TTLTRG1)
D2	Enable Gate out signal on backplane connector P2 A 24 (TTLTRG2)
D3	Enable Gate out signal on backplane connector P2 C 24(TTLTRG3)
D4	Enable Gate out signal on backplane connector P2 A 26 (TTLTRG4)
D5	Enable Gate out signal on backplane connector P2 C 26 (TTLTRG5)
D6	Enable Gate out signal on backplane connector P2 A 27 (TTLTRG6)
D7	Enable Gate out signal on backplane connector P2 C 27 (TTLTRG7)
<u>D8</u>	Disable Gate output (Default)
<u>DD</u>	Disables Time Interval Delay
DE	Enables Time Interval Delay
*ESE?	Query the Standard Event Status Enable Register, response 0 -255
*ESE <Nrf>	Set the mask of the Event Status Enable Register 0 - 255
*ESR?	Query the Standard Event Status Register, response 0 - 255
<u>FA</u>	Selects Frequency A measurement mode
FB	Selects Frequency B measurement mode
FC	Selects Frequency C measurement mode

Table 3.20 - Alphabetical List of 2251A Command Codes (continued)

CODE	RESPONSE
FT	Selects Fall Time A measurement mode
*IDN?	Identification Query, response is a ID string.
<u>IP</u>	Instrument Preset. Sets the 2251A to its power-up (Default) state. Refer to Table 3-1 for further details of the power-up state.
<u>MD</u>	Disables Math function (Default)
ME	Enables Math function
<u>NA</u>	Disables 100 Sample Averaging mode
NW	Selects Negative pulse width A measurement mode
*OPC	Operation Complete, sets Op Complete bit of the ESR
*OPC?	Query for when all operations are complete, response = 1
*OPT?	Query for Channel C option installed, 0 = no, 1 = yes
PA	Selects Period A measurement mode
PH	Selects Phase A relative to B measurement mode
PW	Selects Positive Pulse Width A measurement mode
<u>Q0</u>	SRQ assertion UNCONDITIONALLY inhibited
Q1	SRQ assertion upon error detection
Q2	SRQ asserted for measurement ready
Q3	SRQ asserted for measurement ready or error detection
Q4	SRQ asserted for frequency standard change
Q5	SRQ asserted for frequency standard change or error detection
Q6	SRQ asserted for frequency standard change or measurement ready
Q7	SRQ asserted for frequency standard change or error detection or measurement ready.
R0	External arm input Receiver on backplane connector P2 A 23 TTLTRG0
R1	Enable external arm input on backplane connector P2 C 23 (TTLTRG1)
R2	Enable external arm input on backplane connector P2 A 24 (TTLTRG2)

Table 3.20 - Alphabetical List of 2251A Command Codes (continued)

CODE	RESPONSE
R3	Enable external arm input on backplane connector P2 C 24 (TTLTRG3)
R4	Enable external arm input on backplane connector P2 A 26 (TTLTRG4)
R5	Enable external arm input on backplane connector P2 C 26 (TTLTRG5)
R6	Enable external arm input on backplane connector P2 A 27 (TTLTRG6)
R7	Enable external arm input on backplane connector P2 C 27 (TTLTRG7)
<u>R8</u>	Enable external arm input on front panel (Input D)
RA	Selects Ratio A/B measurement mode
RC	Selects Ratio C/B measurement mode
RDT	Recalls arming delay time
RE	Resets measurement
RF	Reads total so far
RGS	Recalls VXibus Processor Software issue number
RGT	Recalls Gate time
RLA	Recalls Input A trigger level
RLB	Recalls Input B trigger level
RMn	Recalls memory setting n. Sets the 2251A to a previously stored configuration. n=0 to 9. Note all stored settings are lost on powering down the 2251A. 2251A configurations are stored by the SMn command code.
RMS	Recalls master software issue number
RMX	Recalls Math constant X
RMY	Recalls Math constant Y
RMZ	Recalls Math constant Z
RRS	Recalls measurement resolution
RSF	Recalls special function number
*RST	Instrument Rreset. Sets the 2251A to its power-up (Default) state. Refer to Table 3-1 for further details of the power-up state.

Table 3.20 - Alphabetical List of 2251A Command Codes (continued)

CODE	RESPONSE
RT	Selects Rise Time A measurement mode
RUT	Recalls unit type
<u>S10</u>	Selects Arming mode. Start: Internal Stop: Internal (Default)
S11	Selects Arming mode. Start: External +ve Stop: Internal
S12	Selects Arming mode. Start: External -ve Stop: Internal
S15	Selects Arming mode. Start: External +ve Stop: External +ve
S16	Selects Arming mode. Start: External +ve Stop: External -ve
S17	Selects Arming mode. Start: External -ve Stop: External +ve
S18	Selects Arming mode. Start: External -ve Stop: External -ve
<u>S20</u>	Selects default configuration of Input A and B/Cancels S21 (Default)
S21	Interchanges Inputs A and B
<u>S30</u>	Selects continuous auto-trigger measurement (Cancels S31)
S31	Selects single shot auto-trigger measurement
<u>S50</u>	Selects Mean Amplitude measurement mode (Cancels S51 or S52)
S51	Selects Positive Peak amplitude measurement mode
S52	Selects Negative Peak amplitude measurement mode
<u>S60</u>	Selects Totalize A by B measurement mode when function code TA is written (Cancels S61)
S61	Selects Manual Totalize measurement mode when function code TA is written
<u>S70</u>	Check mode which measures internal 10MHz reference is enabled when CK has been written to the 2251A (Cancels S71 to S78)
S72	START TEC short continuous calibration (must be in CK mode)
S73	START TEC long continuous calibration (must be in CK mode)
S74	STOP TEC short calibration (must be in CK mode)
S75	STOP TEC long calibration (must be in CK mode)

Table 3.20 - Alphabetical List of 2251A Command Codes (continued)

CODE	RESPONSE
S76	Checks Inputs A and B DACs. DACs continuously ramped (must be in CK mode)
S77	Input A relay check. Requires a 10 MHz input signal. Refer to Section 5.1.7 . (must be in CK mode)
S78	Checks Input B relay. Requires a 10 MHz input signal. Refer to Section 5.1.7 (must be in CK mode)
<u>S80</u>	Allows two character function header on output string (Cancels S81)
S81	Turn off two character header on output string
SDTn	Sets arming delay time to n seconds. The permitted range for n is $800\text{mS} > n > 200 \mu\text{s}$
<u>SFD</u>	Disables special functions
SFE	Enables special functions. Used with S10 - S81
SGTn	Sets Gate time to n seconds. Refer to Section 3.3.2 for a description of the relationship between resolution and gate time.
SLAv	Sets Input A trigger level to v Volts. The permitted range of values for v is -5.1 V to +5.1 V if X1 input attenuation is selected or -51 to +51 V if X10 input attenuation is selected. Increments of 20 mV and 200 mV are permitted in the X1 and X10 input attenuation modes.
SLBv	Sets Input B trigger level to v Volts. The permitted range of values for v is -5.1 V to +5.1 V if X1 input attenuation is selected or -51 to +51 V if X10 input attenuation is selected. Increments of 20 mV and 200 mV are permitted in the X1 and X10 input attenuation modes.
SMn	Stores the present configuration of the 2251A in RAM memory location n. n=0 to 9. Stored settings are recalled by the RMn command code. Note all stored settings are lost on powering down the 2251A.
SMXa	Sets Math constant X to value a. The permitted ranges of values for a are $1 \times 10^{10} > a \geq 1 \times 10^{-9}$ and $-1 \times 10^{-9} \geq a > -1 \times 10^{10}$. a=0 is also permitted.
SMYa	Sets Math constant Y to value a. The permitted ranges of values for a are $1 \times 10^{10} > a \geq 1 \times 10^{-9}$ and $-1 \times 10^{-9} \geq a > -1 \times 10^{10}$. a=0 is permitted.

Table 3.20 - Alphabetical List of 2251A Command Codes (continued)

CODE	RESPONSE
SMZa	Sets Math constant Z to value a. The permitted ranges of values for a are $1 \times 10^{10} > a \geq 1 \times 10^{-9}$ and $-1 \times 10^{-9} \geq a > -1 \times 10^{10}$. a=0 is permitted to be set, but an error message will be output when the Math function is enabled.
*SRE?	Query the Service Request Enable Register, response is 0 - 255
*SRE <Nrf>	Set the Service Request Enable (mask) Register, <Nrf> = 0 - 255
SRSm	Sets measurement resolution. m is an integer between 3 and 10. Refer to Section 3.3.2 for a description of the relationship between resolution and gate time.
*STB?	Query the Status Byte Register, response is 0 to 113. Bit0 = DDSB, Bit4 = Message Available, Bit5 = Event Status Bit, Bit6 = RQS/MSS Bit.
<u>T0</u>	Selects continuous measurement mode
T1	Selects single shot measurement mode
T2	Starts Manual Totalize or triggers a measurement cycle when in T1, single shot mode
T3	Stops Manual Totalize
TA	Selects Total A by B measurement mode
TI	Selects Time Interval measurement mode
*TRG	Trigger the 2251A to start a reading. Use with T1 mode
*TST?	Command the 2251A to do a Internal Self Test, response 0 = pass, 1 = fail
*WAI	Cause the 2251A to complete all pending commands before continuing

SECTION 4

PERFORMANCE VERIFICATION

4.1 Performance Verification Procedures (PVPs)

4.1.1 This section provides the procedures necessary to verify that the 2251A conforms to its published specifications. It is recommended that these procedures are carried out at a minimum interval of one year.

4.1.2 The following conditions must be kept throughout the Verification Procedure.

a) The instrument covers must be fitted.

b) The ambient temperature must be $23\text{ }^{\circ}\text{C} \pm 2\text{ }^{\circ}\text{C}$

c) The counter must be allowed to warm up for at least one hour before commencing the PVPs.

4.1.3 In the following procedures, a stable count is defined as one that does not vary by more than \pm one count in the least significant digit of resolution between successive readings.

4.1.3.1 Note that these procedures verify the measurement circuitry of the counter but not the absolute accuracy. Absolute accuracies must be calculated from the expressions given in the Specifications section of this manual after finding the timebase errors that apply to the external frequency standard or CLK10 signals used by the counter.

4.1.4 Required Test Equipment

4.1.4.1 Signal Generator, 10 kHz to 1.3 GHz, Racal Instruments 9087

4.1.4.2 Function Generator, DC to 10 kHz, HP 3325

4.1.4.3 DC Voltage Calibrator, Fluke 332A

4.1.4.4 Digital Multimeter, $\pm 5\%$ Accuracy, DC to 100 kHz, Racal Instruments 5001

4.1.4.5 RF Millivoltmeter, Racal Instruments 9303

4.1.4.6 Various RF connectors, adaptors, T-pieces and coaxial cables, as required.

NOTE

In the following procedures, it is recommended that all signal levels are measured with the Digital Multimeter or RF Millivoltmeter, as appropriate, and adjusted to give a level as close to its nominal value as can be achieved before being applied to the counter.

4.1.5 Diagnostic Special Functions

4.1.5.0.1 It is recommended that the following Special Functions are enabled in turn in the check mode and the results noted before commencing the Performance Verification Procedures for the counter. Successful completion of this procedure demonstrates that the 2251A measurement circuitry is functioning correctly.

- S70 Frequency Measurement Check. Expected result: CK+10.000000000e+06
- S72 START TEC Short Calibration.
- S73 START TEC Long Calibration.
- S74 STOP TEC Short Calibration.
- S75 STOP TEC Long Calibration.
- S77 Input A relays check
- S78 Input B relays check.

The expected results for S73 and S75 are 800 ± 220 . The expected results for S72 and S74 are (S73 result) / 2, tolerance +20, -40 and (S75 result) / 2, tolerance + 20, -40, respectively.

For S77 and S78 tests, it is necessary to input a 10MHz square wave signal with amplitude of a positive peak between +.8V and +1.0V, and a negative peak between -.2V and -.4V Ω . A successful completion of the relays results in an output of CK+0000000000.0E000. Error Codes are described in Section 3.4.

4.1.5.0.2 Check mode Special Functions S72 - S78 may be exited by selecting S70 (Basic Check function) or any other measurement mode.

4.1.5.3 Special Functions S77 and S78 require a time delay between initiation of check and reading of data. S77 requires a 9 second delay and S78 requires a 1 second delay.

4.1.6 **Input A Sensitivity Test**

4.1.6.0.1 Set the 2251A to its home state. Select 50 ohms input impedance for input A and external frequency standard.
(Command String: IP ALI B1)

If Option 11 is installed connect the 2251A internal reference output to the external signal source 10 MHz Input. Configure the external signal source to accept the 10MHz reference from the 2251A.
(Command String: IP ALI)

4.1.6.1 Connect the Function Generator to the 2251A as shown in **Figure 4-1**.

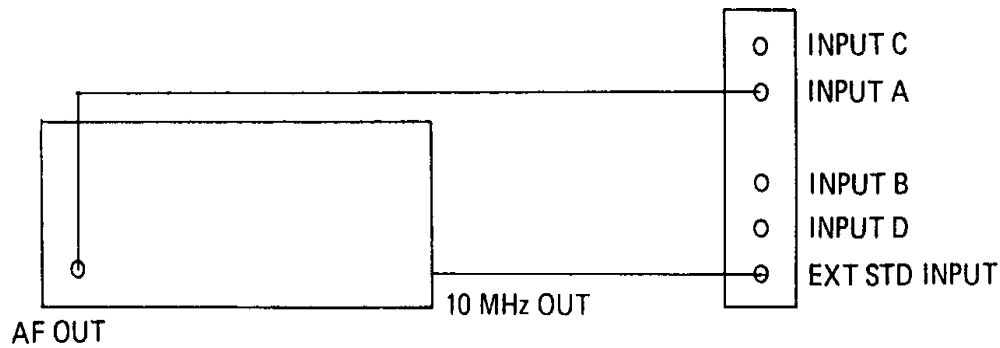

Figure 4-1, Input A Low Frequency Sensitivity Test Configuration

4.1.6.2 Apply the frequencies given in **Table 4-1** to the counter. Verify that the 2251A gives a stable reading within the tolerances given at less than the signal levels given.

Frequency	Signal level	Resolution	Tolerance
10 Hz	25 mV rms	8	± 1 Hz
5 kHz	25 mV rms	8	± 0.1 Hz
10 kHz	25 mV rms	8	± 0.1 Hz

Table 4-1, Input A Sensitivity Low Frequency Test

4.1.6.3 Disconnect the test equipment.

If Option 11 is installed connect the 2251A internal reference output to the external signal source 10 MHz Input. Configure the external signal source to accept the 10MHz reference from the 2251A.

4.1.6.4 Connect the Signal Generator to the 2251A as shown in **Figure 4-2**.

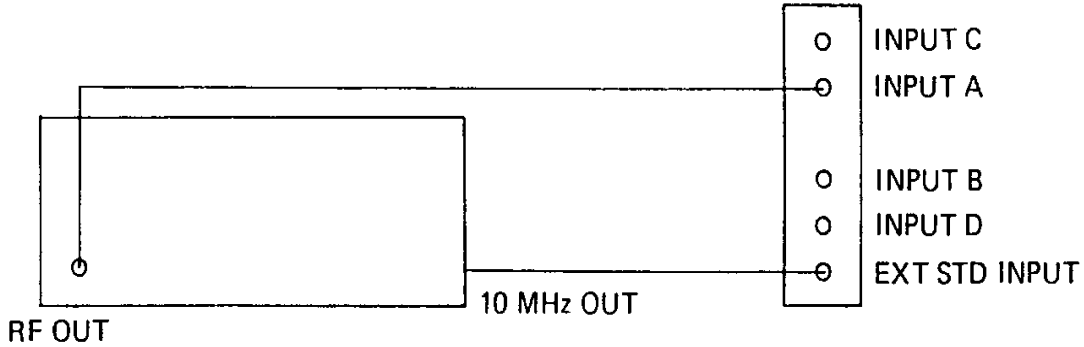

Figure 4-2, Input A High Frequency Sensitivity Test Configuration

4.1.6.5 Set the 2251A measurement resolution to the values given in **Table 4-2** and apply the frequencies given to the counters input A. Verify that the 2251A gives a stable reading within the tolerances given at less than the signal level given.

Frequency	Signal level	Resolution	Tolerance
200 MHz	50 mV rms*	9	± 1 Hz
160 MHz	50 mV rms	9	± 1 Hz
100 MHz	25 mV rms	9	± 1 Hz
10 MHz	25 mV rms	8	± 1 Hz
100 kHz	25 mV rms	8	± 0.1 Hz

* Valid up to 30°C

Table 4-2, Input A Sensitivity High Frequency Performance Limits

4.1.6.6 Disconnect the test equipment.

4.1.7 Input B Sensitivity Test

- 4.1.7.0.1 Set the 2251A to its home state. Select 50 ohms input impedance for input B, Frequency B as the measurement mode and external frequency standard.
(Command String: IP FB B1 BLI)

If Option 11 is installed connect the 2251A internal reference output to the external signal source 10 MHz Input. Configure the external signal source to accept the 10MHz reference from the 2251A. (Command String: IP FB BLI)

- 4.1.7.1 Connect the Function Generator to the 2251A as shown in **Figure 4-3**.

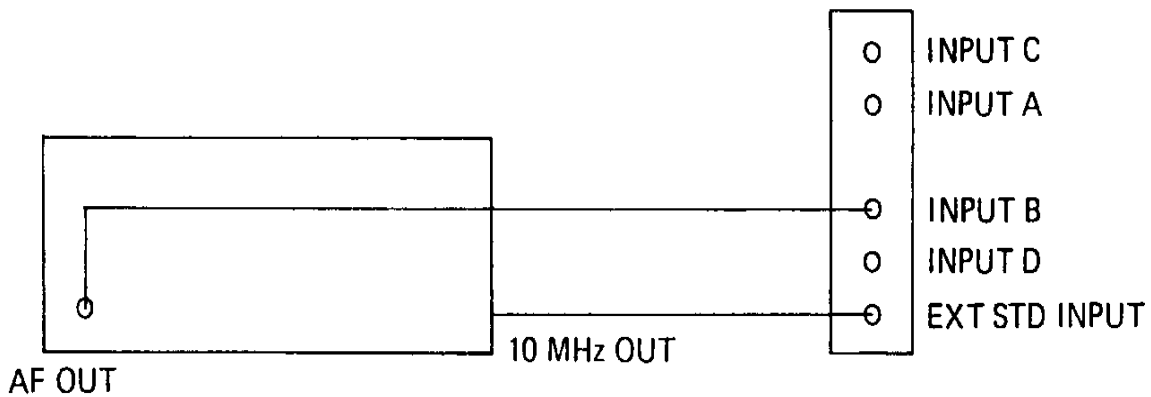

Figure 4-3, Input B Low Frequency Sensitivity Test Configuration

- 4.1.7.2 Apply the frequencies given in **Table 4-3** to the counters input B. Verify that the 2251A gives a stable reading within the tolerances given at less than the signal level given.

Frequency	Signal level	Resolution	Tolerance
10 Hz	25 mV rms	8	± 1 Hz
5 kHz	25 mV rms	8	± 0.1 Hz
10 kHz	25 mV rms	8	± 0.1 Hz

Table 4-3, Input B Sensitivity Low Frequency Performance Limits

- 4.1.7.3 Disconnect the test equipment.

If Option 11 is installed connect the 2251A internal reference output to the external signal source 10 MHz Input. Configure the external signal source to accept the 10MHz reference from the 2251A.

4.1.7.4 Connect the Signal Generator to the 2251A as shown in **Figure 4-4**.

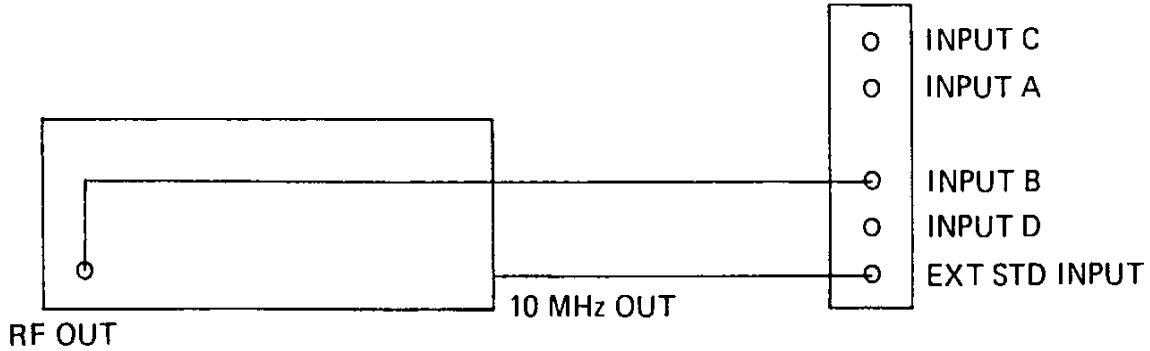

Figure 4-4, Input B High Frequency Sensitivity Test Configuration

4.1.7.4.1 Set the 2251A measurement resolution to the values given in **Table 4-4** and apply the frequencies given in **Table 4-4** to the counters input B. Verify that the 2251A gives a stable reading within the tolerances given at less than the signal levels given.

Frequency	Signal level	Resolution	Tolerance
160 MHz	50 mV rms	9	± 1 Hz
100 MHz	25 mV rms	9	± 1 Hz
10 MHz	25 mV rms	8	± 1 Hz
100 kHz	25 mV rms	8	± 0.1 Hz

Table 4-4, Input B Sensitivity High Frequency Performance Limits

4.1.7.5 Disconnect the test equipment.

4.1.8 Input C Sensitivity Test

4.1.8.1 This section applies only to 2251As fitted with Option 41 (Input C)

4.1.8.1.1 Set the 2251A to its home state. Select Frequency C as the measurement mode and external frequency standard.
(Command String: IP FC B1)

If Option 11 is installed connect the 2251A internal reference output to the external signal source 10 MHz Input. Configure the external signal source to accept the 10MHz reference from the 2251A.
(Command String: IP FC)

4.1.8.1.2 Connect the Signal Generator to the counter as shown in **Figure 4-5**.

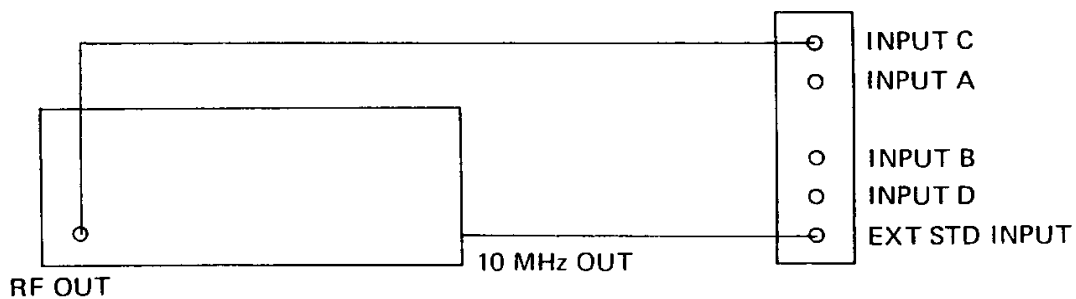

Figure 4-5, Input C Test Configuration

4.1.8.1.3 Set the 2251A measurement resolution to the values given in **Table 4-5** and apply the frequencies given in **Table 4-5** to the counter's input C. Verify that the 2251A gives a stable reading within the tolerances given at less than the signal levels given.

Frequency	Signal level	Resolution	Tolerance
40 MHz	10 mV rms	8	± 1 Hz
100 MHz	10 mV rms	9	± 1 Hz
500 MHz	10 mV rms	9	± 1 Hz
1.0 GHz	10 mV rms	9	± 2 Hz
1.3 GHz	50 mV rms	9	± 2 Hz

Table 4-5, Input C Sensitivity Performance Limits

4.1.8.2 Disconnect the test equipment.

4.1.9 Time Interval A-B Test

4.1.9.0.1 Set the 2251A to its home state. Select Time Interval A-B as the measurement mode, 50 ohms for input A input impedance, Common mode for inputs A and B and external frequency standard.

(Command String: IP TI ALI BCC B1)

If Option 11 is installed connect the 2251A internal reference output to the external signal source 10 MHz Input. Configure the external signal source to accept the 10MHz reference from the 2251A.

(Command String: IP TI ALI BCC)

4.1.9.0.2 Connect the 2251A to the signal generator as shown in **Figure 4-6**. Set the signal generator to 10 MHz, 0 dBm.

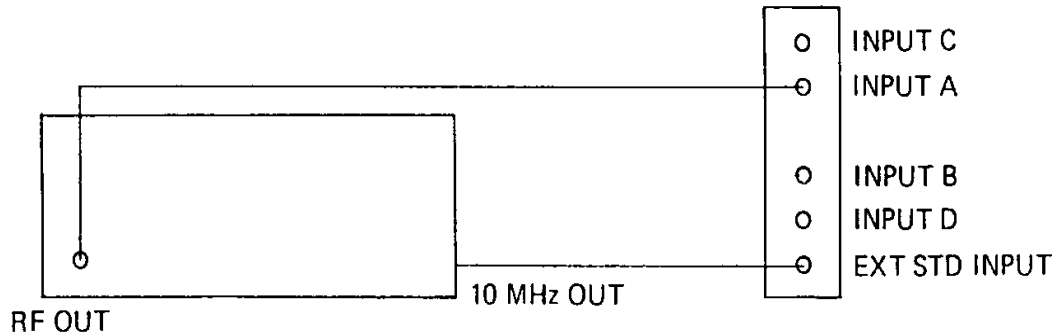

Figure 4-6, Time Interval A-B Test Configuration

4.1.9.1 Set the counter input trigger slopes as shown in **Table 4-6** and verify that the counters measurement result is as given in **Table 4-6**.

Input A Slope	Input B Slope	Result	Tolerance
+	+	0 ns	± 2ns
-	+	50 ns	± 2ns
-	-	0 ns	± 2ns
+	-	50 ns	± 2ns

Table 4-6, Time Interval A-B Test Performance Limits

4.1.9.2 Disconnect the test equipment.

4.1.10 Totalize A by B Test

4.1.10.1 Set the 2251A to its home state. Select Totalize A by B as the measurement mode, 50 ohms input A input impedance and external frequency standard.
(Command String: IP TA ALI B1)

If Option 11 is installed connect the 2251A internal reference output to the external signal source 10 MHz Input. Configure the external signal source to accept the 10MHz reference from the 2251A.

(Command String: IP TA ALI)

4.1.10.2 Connect the 2251A to the signal generator as shown in **Figure 4-7**. Set the signal generator to 10 MHz, 0 dBm. Verify that the counters measurement result is 10000 ± 1 .

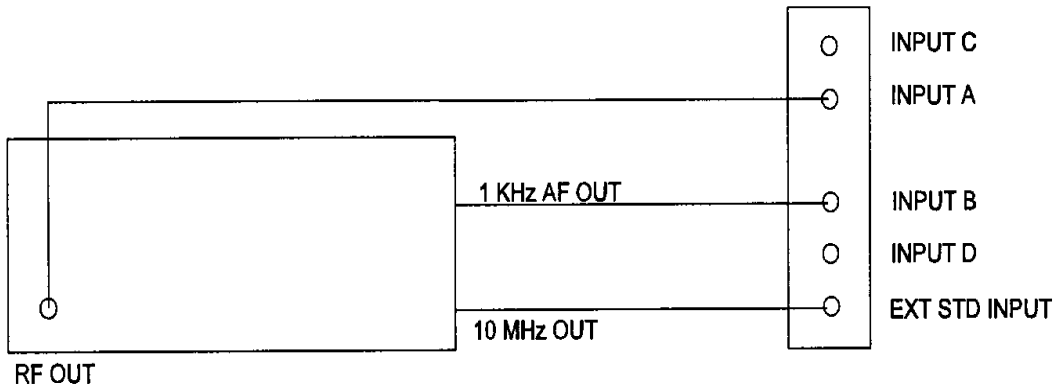

Figure 4-7, Totalize A by B Test Configuration

4.1.10.3 Disconnect the test equipment.

4.1.11 Ratio A/B Test

4.1.11.1 Set the 2251A to its home state. Select Ratio A/B as the measurement mode, 50 ohms for input A input impedance, DC input coupling for input B, external frequency standard and set the measurement resolution to three digits.
(Command String: IP RA ALI SRS3)

4.1.11.2 Connect the 2251A to the signal generator as shown in **Figure 4-8**. Set the signal generator to 50 MHz, 100 mV rms. Verify that the counters measurement result is 50000 ± 10 .

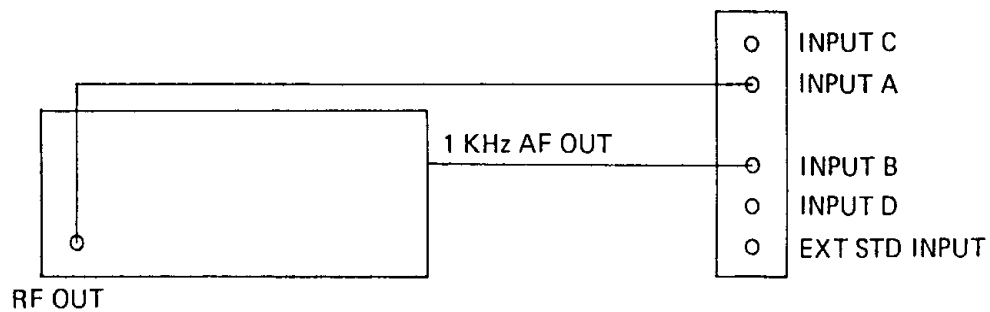

Figure 4-8, Ratio A / B Test Configuration

4.1.11.3 Disconnect the test equipment.

4.1.12 Ratio C/B Test

4.1.12.1 Set the 2251A to its home state. Select Ratio C/B as the measurement mode, DC input coupling for input B, external frequency standard and set the measurement resolution to six digits.

(Command String: IP RC ALI SRS6)

4.1.12.2 Connect the 2251A to the signal generator as shown in **Figure 4-9**. Set the signal generator to 50 MHz, 100 mV rms. Verify that the counters measurement result is 50000 ± 10 .

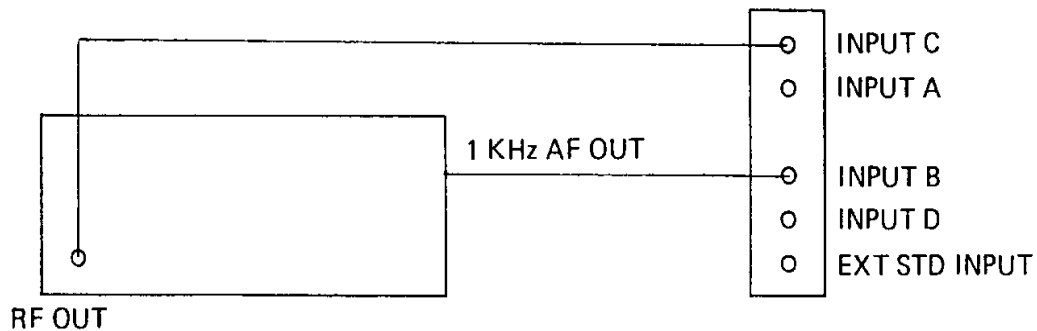

Figure 4-9, Ratio C / B Test Configuration

4.1.12.3 Disconnect the test equipment.

4.1.13 Trigger Level Accuracy Test

- 4.1.13.1 Set the 2251A to its home state. Set the counter to DC input coupling for input A and enable special functions.
(Command String: IP ADC SFEEAAU)
- 4.1.13.2 Connect the counter to the DC standard as shown in **Figure 4-10** and set the DC Standard output voltage to 5.000 V.

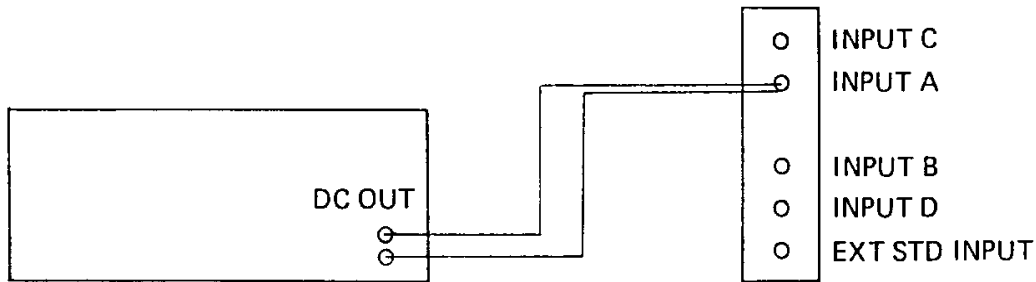

Figure 4-10, Input A Trigger Level Test Configuration

- 4.1.13.3 Connect the DC Standard to input A of the counter. Single shot autotrigger the counter (Command code S31). Recall the 2251A stored trigger level (Command code RLA) and verify that it is $5.000\text{ V} \pm 80\text{ mV}$.
- 4.1.13.4 Reverse the polarity of the DC input to the counter, single shot autotrigger the counter and recall the stored trigger level value. Verify that it is $-5.000\text{ V} \pm 80\text{ mV}$.
- 4.1.13.5 Set the 2251A to its home state. Set the counter to DC input coupling for input B and enable special functions.
(Command String: IP BDC SFEBAAU)
- 4.1.13.6 Connect the DC Standard to input B of the counter as shown in **Figure 4-11**. Single shot autotrigger the counter. Recall the 2251A stored trigger level (Command code RLB) and verify that it is $5.000\text{ V} \pm 80\text{ mV}$.

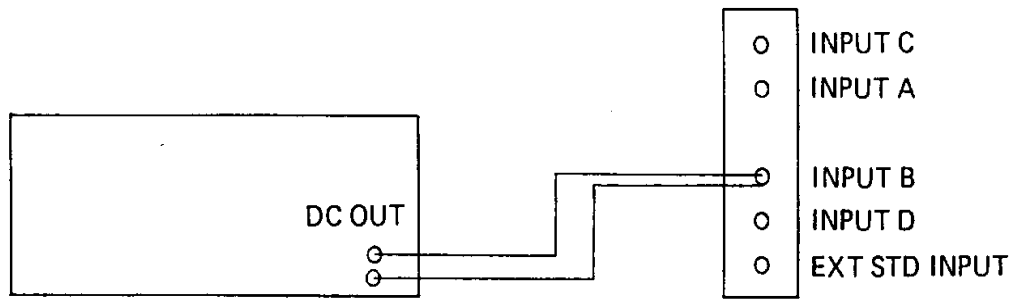

Figure 4-11, Input B Trigger Level Test Configuration

- 4.1.13.7 Reverse the polarity of the DC input to the counter, trigger the measurement and recall the stored trigger level value. Verify that it is $-5.000\text{ V} \pm 80\text{ mV}$.
- 4.1.13.8 Disconnect the test equipment.

4.2 Functional Checks

4.2.1 Input A Filter Check

- 4.2.1.1 Set the counter to its home state. Select 50 ohms input impedance for input A.
(Command code: IP ALI)
- 4.2.1.2 Connect the counter to the signal generator as shown in **Figure 4-12**.

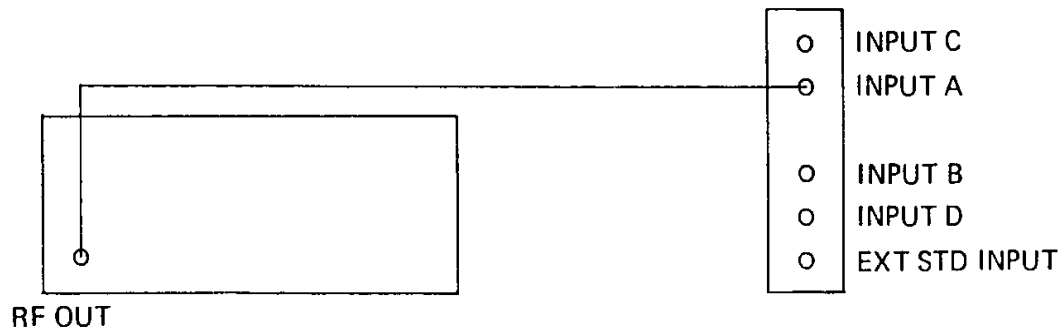

Figure 4-12, Input A Filter Check Configuration

- 4.2.1.3 Set the signal generator to 50 kHz, 10 mV. Increase the signal generator output level until the counter gives a stable reading. Note the signal generator output level.
- 4.2.1.4 Enable the counter's input A filter (Command code AFE) and verify that the 2251A no longer counts. Increase the signal generator until the counter gives a stable reading. Note the signal generator output level and verify that this level is approximately twice the level previously noted.
- 4.2.1.5 Disconnect the test equipment.

4.2.2 Input A Attenuator Check

- 4.2.2.1 Set the counter to its home state. Select 50 ohms input impedance for input A.
(Command code: IP ALI)
- 4.2.2.2 Connect the counter to the signal generator as shown in **Figure 4-13**.

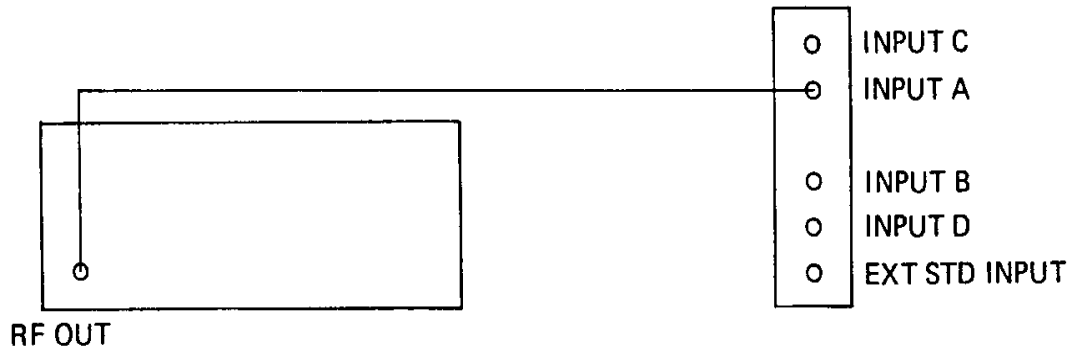

Figure 4-13, Input A X10 Attenuator Check Configuration

- 4.2.2.3 Set the signal generator to 1 MHz, 10 mV. Increase the signal generator output level until the counter gives a stable reading. Note the signal generator output level.
- 4.2.2.4 Enable the counter's input A attenuator (Command code AAE) and verify that the 2251A no longer counts. Increase the signal generator until the counter gives a stable reading. Note the signal generator output level and verify that this level is approximately ten times the level previously noted.
- 4.2.2.5 Disconnect the test equipment.

4.2.3 Input B Attenuator Check

- 4.2.3.1 Set the counter to its home state. Select Frequency B as the measurement mode and 50 ohms input impedance for input B.
(Command code: IP FB BLI)
- 4.2.3.2 Connect the counter to the signal generator as shown in **Figure 4-14**.

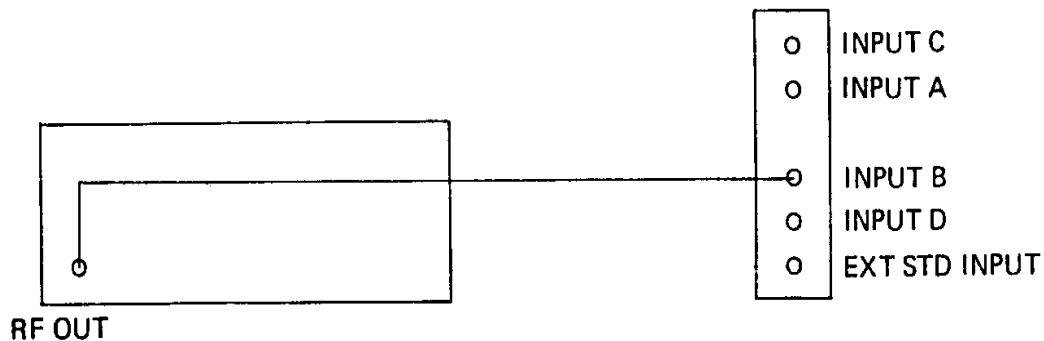

Figure 4-14, Input B X10 Attenuator Check Configuration

- 4.2.3.3 Set the signal generator to 1 MHz, 10 mV. Increase the signal generator output level until the counter gives a stable reading. Note the signal generator output level.
- 4.2.3.4 Enable the counter's input B attenuator (Command code BAE) and verify that the 2251A no longer counts. Increase the signal generator until the counter gives a stable reading. Note the signal generator output level and verify that this level is approximately ten times the level previously noted.
- 4.2.3.5 Disconnect the test equipment.

4.3 Disassembly Instructions

- 4.3.1 Remove the three panhead screws that secure the aluminum cover to the counter body.
- 4.3.2 Slide the cover along the channel that it sits in, towards the rear of the counter and remove the cover.
- 4.3.3 Remove the ten panhead screws that secure the 2251A bottom cover to the counter side extrusions, five on each side.
- 4.3.4 Remove the three countersunk screws that secure the cover to the counter.
- 4.3.5 Slide the cover along the channel that it sits in, towards the rear of the counter and remove the cover. The 2251A PCB is now exposed sufficiently to allow all maintenance procedures to be carried out.

CAUTION

**The 2251A contains static sensitive devices.
Observe all Electrostatic Discharge precautions
while the counter is disassembled.**

4.4 Reassembly Instructions

- 4.4.1 Align the bottom cover with the channels in the side extrusions of the counter and slide the cover along the channels.
- 4.4.2 Secure the cover to the counter body with the thirteen screws obtained on the removal of the bottom cover, five along each edge and three on the centerline of the cover.
- 4.4.3 Align the top cover with the channels in the side extrusions of the counter and slide the cover along the channels.
- 4.4.4 Secure the cover to the counter body with the three panhead screws obtained on removal of the cover.

4.5 2251A Input Amplifier Setup Procedure

4.5.1 Introduction

4.5.1.1 This section provides the setup procedures that are to be carried out after repair of the 2251A or the failure of a routine specification check.

4.5.1.2 All setup procedures are to be carried out with the counters covers removed, at an ambient temperature of $23^{\circ}\text{C} \pm 2^{\circ}\text{C}$. The counter must be allowed to warm up for a minimum of 1 hour before commencing any setup procedure. The procedures given here commence with the counter in the Home state.

4.5.1.3 It is recommended that the counter is read repeatedly and the current measurement result displayed by the controller used while adjusting the counters input amplifiers to obtain a stable count.

4.5.2 Input A Amplifier Setup Procedure

4.5.2.1 Set R12 fully counterclockwise and R10 to its midposition. R10 and R12 are located on the counter PCB as shown in **Figure 4-15**.

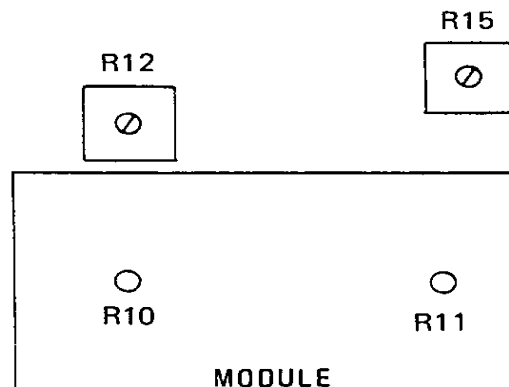

Figure 4-15, Location of R10, R11, R12 and R15

4.5.2.2 Select Frequency A as the measurement function, set Input A input impedance to 50 ohms and set the counter resolution to three digits. (Command Code FA ALI SRS3 BI)

If Option 11 is installed connect the 2251A internal reference output to the external signal source 10 MHz Input. Configure the external signal source to accept the 10MHz reference from the 2251A.
(Command String: FA ALI SRS3)

4.5.2.3 Connect the counter to the signal generator as shown in **Figure 4-16**.

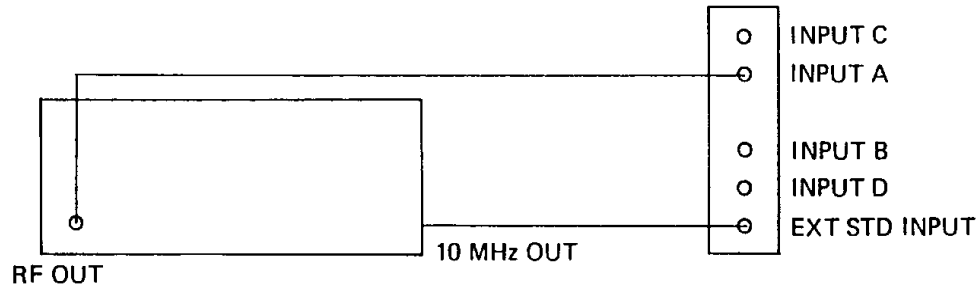

Figure 4-16, Input A Amplifier Setup Configuration

4.5.2.4 Set the signal generator output to 100 MHz, 3.0 mV rms

4.5.2.5 Adjust R10 to obtain a stable reading of 100 MHz \pm 0.1 MHz. Verify that the counters GATE LED is flashing.

4.5.2.6 Turn off the RF output of the signal generator.

4.5.2.7 Set the counter resolution to eight digits (Command code SRS8).

4.5.2.8 Increase the signal generator output level to 13 mV rms.

4.5.2.9 Adjust R12 slowly clockwise until the counter measurement result starts to become unstable. Turn R12 slowly counterclockwise until the counter measurement result is stable, value 100 MHz \pm 1Hz.

4.5.2.10 Reduce the signal generator output level to 7 mV rms and verify that the GATE LED stops flashing. If the LED continues to flash, repeat steps 5.5.3.8 to 5.5.3.10.

4.5.2.11 Disconnect the test equipment.

4.5.3 Input B Amplifier Setup Procedure

4.5.3.1 Set R15 fully counterclockwise and R11 to its midposition. R11 and R15 are located on the counter PCB as shown in **Figure 4-15**.

4.5.3.2 Select Frequency B as the measurement function, set Input B input impedance to 50 ohms and set the counter resolution to three digits. (Command Code FB BLI SRS3 BI)

If Option 11 is installed connect the 2251A internal reference output to the external signal source 10 MHz Input. Configure the external signal source to accept the 10MHz reference from the 2251A. (Command String: FB BLI SRS3)

4.5.3.3 Connect the counter to the signal generator as shown in **Figure 4-17**.

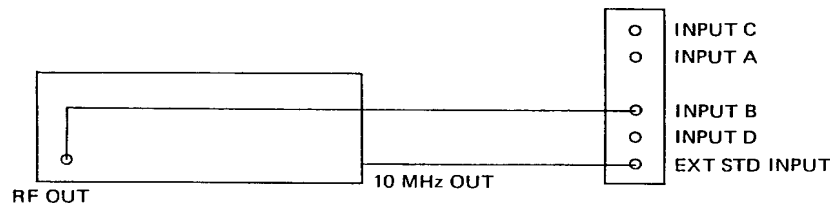

Figure 4-17, Input B Amplifier Setup Configuration

4.5.3.4 Set the signal generator output to 100 MHz, 3.0 mV rms.

4.5.3.5 Adjust R11 to obtain a stable reading of 100 MHz \pm 0.1 MHz. Verify that the counters GATE LED is flashing.

4.5.3.6 Turn off the RF output of the signal generator.

4.5.3.7 Set the counter resolution to eight digits (Command code SRS8)

4.5.3.8 Increase the signal generator output level to 13 mV rms.

4.5.3.9 Adjust R15 slowly clockwise until the counter measurement result starts to become unstable. Turn R15 slowly counterclockwise until the counter measurement result is stable, value 100 MHz \pm 1Hz.

4.5.3.10 Reduce the signal generator output level to 7 mV rms and verify that the GATE LED stops flashing. If the LED continues to flash, repeat steps 5.5.4.8 to 5.5.4.10.

4.5.3.11 Disconnect the test equipment.

4.5.4 Input C Amplifier Setup Procedure

If Option 11 is installed connect the 2251A internal reference output to the external signal source 10 MHz Input. Configure the external signal source to accept the 10MHz reference from the 2251A.

4.5.4.1 Connect the signal generator to the counter as shown in **Figure 4-18**.

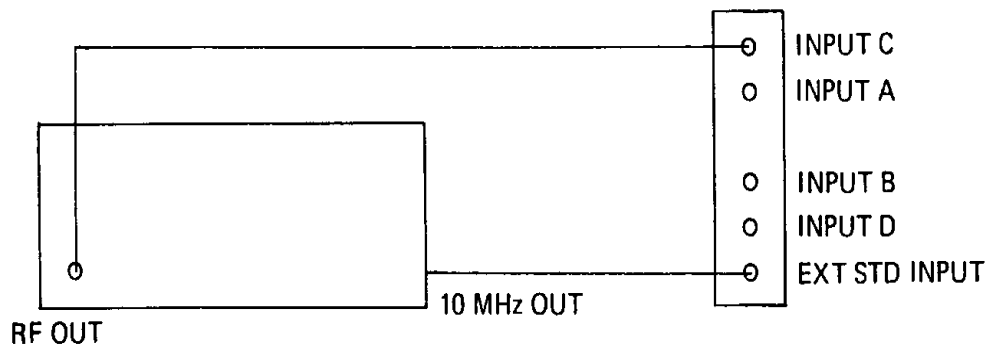

Figure 4-18, Input C Setup Configuration

- 4.5.4.2 Set R27 on the Channel C amplifier board fully clockwise.
- 4.5.4.3 Select Frequency C as the measurement function (Command code FC).
- 4.5.4.4 Set the signal generator output to 1 GHz, 10.0 mV rms.
- 4.5.4.5 Adjust R27 slowly clockwise until the GATE LED starts to flash and the measurement result is 1GHz \pm 10 Hz.
- 4.5.4.6 Turn off the signal generator output. Reduce the signal generator output level to 9.0 mV rms.
- 4.5.4.7 Turn on the signal generator output and verify that the 2251A is not counting. If the counter continues to count, repeat steps 5.5.5.4 to 5.5.5.7.
- 4.5.4.8 Disconnect the test equipment.

4.6 Calibration, External Standard Output (2251 with option 11)

4.6.1 Internal Frequency Standard Adjustment

1. Prior to calibration, the 2251 or 2251A must be in continuous operation for 4 hours at an ambient temperature of $25 \pm 2^{\circ}\text{C}$
2. Prior to calibration of the 2251, 2251A (with Option 11) place the module in a chassis which allows access to the frequency adjustment screw (Racal 1264C Chassis) or place the module on an extender card.
3. Connect the master frequency standard (9480/FRS or equivalent) to the EXT STD INPUT of the 2251 Frequency Counter.
4. Connect the 2251A 10MHz (UUT) reference output to INPUT of the 2251A.

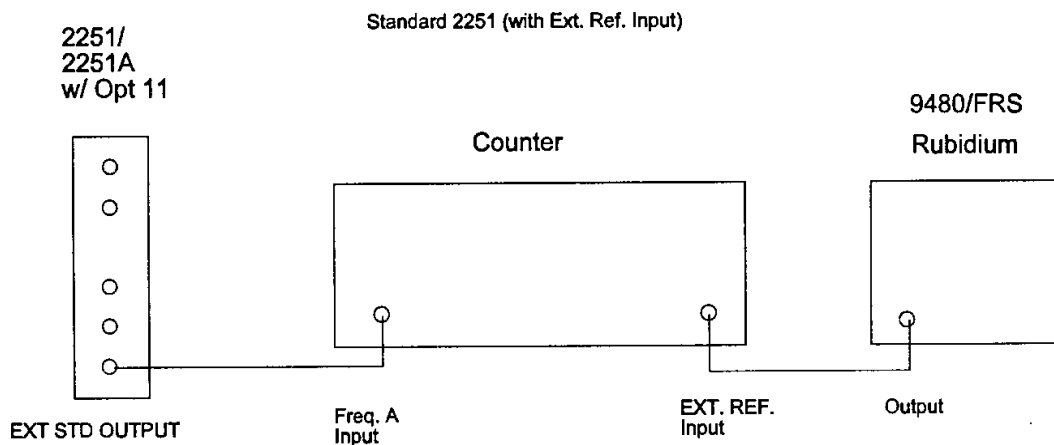

Figure 4-19, External Standard Output

5. Program the 2251 Frequency Counter as follows:
 1. Frequency, Channel A
 2. AC coupled 50 ohm input impedance
 3. Auto-Trigger
 4. External Reference Input
 5. 10 S Gate Time
 6. Enable math function for deviation read-out.
6. Use a screw driver to adjust the Frequency Adjust Screw until a reading of $+10.000000000\text{e}+06$ or FA10MHz is reached.

5.1 Programming Defaults In Automatic Functions

The Model 2251A features a number of automatic functions, Pulse Width (both negative and positive), Rise/Fall Time and Phase. The purpose of these functions is to reduce the amount of code the end user must send to the counter to set up what are really complex measurements. For each of these automatic functions there are a number of default settings, some of which can be changed and some of which are not changeable when the automatic functions are enabled. The default settings are those which the user would have to individually program if the counter did not offer the automatic settings and should therefore be expected. Following are the details of the automatic functions.

The Automatic Functions Commands

The letters in all capital refer to the device-dependent commands for the 2251A. the automatic commands and their device-dependent commands are:

COMMAND	Parameter Set
PW	Positive Pulse Width, defined as the time between the 50% amplitude point of the rising and falling edges of a waveform. See Figure 5-1 .
NW	Negative Pulse Width, defined as the time between the 50% amplitude point of the falling and rising edges of a waveform. See Figure 5-1 .
RT	Rise Time, defined as the time between the 10% and 90% amplitude points on the rising edge of a waveform. See Figure 5-2 .
FT	Fall Time, defined as the time between the 90% and 10% amplitude points on the falling edge of a waveform. See Figure 5-2 .
PH	Phase, calculated as a time interval measurement between the signals on Channels A and B, scaled by the period on the reference channel and normalized for degrees.

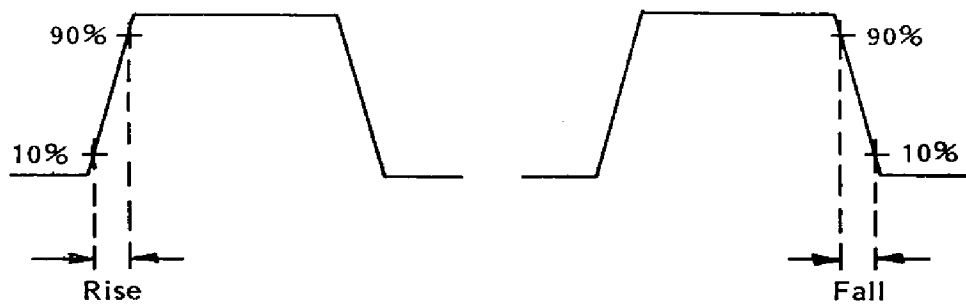

Figure 5-1 Positive/Negative Pulse

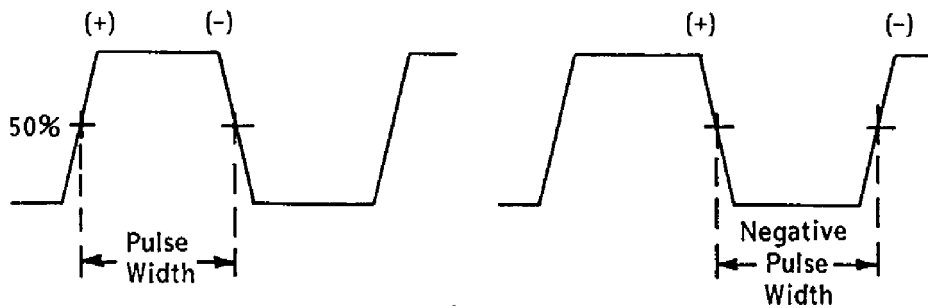

Figure 5-2 Rise/Fall Time

The 2251A, for all of the automatic functions except Phase, defaults to the following signal conditioning parameters:

COMMAND	Parameter Set
BCC	Common Channel B to Channel A
AAU	Auto-trigger Channel A (and Channel B due to Common)
ADC	DC couple Channel A (and Channel B due to Common)
AFD	Filter is disabled on Channel A, the only channel on which it is available.

When in the automatic functions of Pulse Width and Rise/Fall Time, the signal being measured on the 2251A is on a single channel and the Common mode (BCC) is automatically enabled. Channel A and B inputs are internally connected to allow the counter to minimize propagation delay and mismatch. When in Common mode it is not possible to swap Channels A and B. Therefore, Special Function 21 (SFE 21) is not applicable.

The following commands are toggle functions for the default signal conditioning parameters. Sending any of these to the 2251A with most of the automatic commands (PW, NW, RT, FT) enabled will cause the following to occur.

COMMAND	Parameter Set
AAC	The 2251A will enable AC coupling on Channel A (and on Channel B due to Common)
AFE	The 2251A will enable the filter on Channel A. This is not recommended as filtering, and AC coupling will slow down any edges which the user is typically trying to characterize.
AMN	The 2251A will enable manual trigger. The user must take care that the signal level and amplitude does not change as the 2251A is no longer tracking the signal.
AAE	Writing the Channel A X10 Attenuator command to the 2251A will cause a syntax error to be generated. This will result in the Status Byte error bit being set and Error Code number 5 being reported in the Status Byte. The Service Request Interrupt (SRQ) will not be generated unless the 2251A has previously been masked by use of the Q<n> commands to do so.
BCS	The 2251A will disable the Common mode and will expect to see a separate signal on the Channel B input.
BAC	The 2251A will ignore this command as the coupling is controlled by Channel A due to the Common setting.
BMN	The 2251A will ignore this command as the trigger control, either automatic or manual, is controlled by channel A due to the Common command.

Output Format

Measurement data from the 2251A is always output with a two-character header appropriate to the function. The header is the same as the command, e.g., PW for Pulse Width. The two-character header can be disabled by use of the special function 81. The command sequence to do so is "S81SFE". The data output format following the two character header is a polarity sign and a 16-digit number. This number is formatted in engineering notation with a two-digit signed exponent. Leading zeros fill up the empty spaces. When the header is disabled, the first two characters are replaced with spaces.

Pulse Width

The default settings when the Positive Width (PW) command is sent to the 2251A, in addition to the above common settings, are:

COMMAND	Parameter Set
TI	Time Interval
APS	Positive Slope, Channel A
BNS	Negative Slope, Channel B
ADC	DC Coupled, Channel A

The following commands, when sent to the 2251A while Positive Width (PW) is enabled will cause the following changes in setup:

COMMAND	Parameter Set
ANS	The 2251A will change to Negative Width (NW) mode returning a header of NW. Channel A will have negative slope enabled and Channel B will have positive slope enabled.
BPS	The 2251A will change to Negative Width (NW) mode returning a header of NW. Channel A will have negative slope enabled and Channel B will have positive slope enabled.

The default settings for a Negative Pulse Width (NW) command, in addition to the above common settings, are:

COMMAND	Parameter Set
TI	Time Interval
ANS	Negative Slope, Channel A
BPS	Positive Slope, Channel B
ADC	Channel A, DC Coupled

The following commands, when sent to the 2251A while it is in the Negative Width (NW) mode will cause:

COMMAND	Parameter Set
APS	The 2251A will change to Positive Width (PW) mode and return a header of PW. Channel A will have positive slope enabled and Channel B will have negative slope enabled.

BNS The 2251A will change to Positive Width (PW) mode and return a header of PW. Channel A will have positive slope enabled and Channel B will have negative slope enable.

Rise/Fall Time

The default settings, in addition to the above common settings, when the Rise Time (RT) command is sent to the 2251A are:

COMMAND	Parameter Set
TI	Time Interval
APS	Positive Slope, Channel A
BPS	Positive Slope, Channel B
ADC	Channel A, DC Coupled

The following commands, when sent to the 2251A while Rise Time (RT) is enabled will cause:

COMMAND	Parameter Set
ANS	The 2251A will change to Fall Time (FT) with a header of FT, Channels A and B will have a negative slop enabled.
BNS	The 2251A will remain in the Rise Time (RT) mode with a header of RT and Channels A and B with positive slope enabled.

The default settings, in addition to the above common settings, when the Fall Time (FT) command is sent to the 2251A are:

COMMAND	Parameter Set
TI	Time Interval
ANS	Negative Slope, Channel A
BNS	Negative Slope, Channel B
ADC	Channel A, DC coupled

The following commands, when sent to the 2251A while Fall Time (FT) is enabled will cause:

COMMAND	Parameter Set
APS	The 2251A will change to Rise Time (RT) with a header of RT, Channels A and B will have a positive slope enabled.

BPS

The 2251A will remain the Fall Time (FT) mode with a header of FT and Channels A and B will have a negative slope enabled.

Phase Measurement

Phase measurement on the 2251A is a sequence of functions and is accomplished by measuring the time interval between the two signals and calculating the phase as a function of the total Period. This complex measurement is implemented as a series of three measurements: a Ratio A/B or (B/A) to determine if the signals are the same frequency, a Period measurement to determine the period of the reference signal and a Time Interval measurement to determine the time difference between the two signals. The Time Interval is then divided by the Period and the result multiplied by 360 to scale the answer for degrees. (Refer to Figure 5-3.)

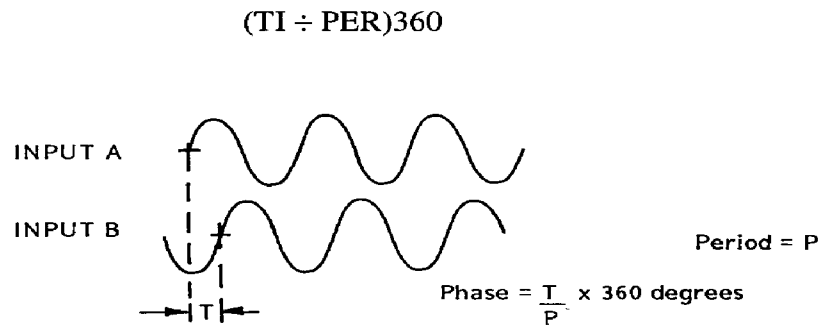

Figure 5-3 Phase Measurement

The default settings for the 2251A in the Phase mode are:

COMMAND	Parameter Set
PH	RA/PA/TI The function is a sequential setting of functions which are not programmable or changeable by the user.
AMN	Manual trigger, Channel A. Channel A auto-trigger (AAU) can be programmed.
BMN	Manual trigger, Channel B. Channel B auto-trigger (BAU) can be programmed.
AAD	X1 attenuator, Channel A. The X1 attenuator is set by default in the manual trigger mode. The X10 attenuator can be set if the signal is larger than 5 V _{p-p} or larger than ±5 V. The attenuator setting will be

programmed automatically in auto-trigger.

BAD X1 attenuator, Channel B. The X1 attenuator is set by default in the manual trigger mode. The X10 attenuator can be set if the signal is larger than $5 V_{p-p}$ or larger than $\pm 5 V$. The attenuator setting will be programmed automatically in auto-trigger.

Phase Mode Default Settings (continued)

COMMAND Parameter Set

AAC AC coupling, Channel A. DC coupling (ADC) can be programmed.

BAC AC coupling, Channel B. DC coupling (BDC) can be programmed.

AFD Filter disabled, Channel A. The filter on Channel A can be enable by the AFE command.

APS Positive slope, Channel A. The slope on Channel A can be changed to negative with the ANS command.

BPS Positive slope, Channel B. The slope on Channel B can be changed to negative with the BNS command.

BCS Separate inputs. It is assumed that the Phase measurement is being made on separate signals. The Common input can be enabled if a single signal is to be characterized with the BCC command.

Summary

To summarize, the automatic functions are designed to reduce the user's setup time by programming the counter's functions and signal conditioning parameters for typical values appropriate to the measurement. For example, most pulse parameter measurements are made on square waves or pulses, which would indicate that the user DC couple the input so as not to slow down the signal and change its integrity prior to measurement. Therefore, in Pulse Width and Rise/Fall Time modes, the 2251A defaults to DC coupling.

Because of the default conditions and disallowed set-up parameters on the automatic functions of the 2251A, care needs to be taken when designing drivers or soft panels to ensure that correct transitions are made when changing functions or signal conditioning parameters.

5.2 Calculating Measurement Cycle Time

Measurement cycle time is a concern in systems that contain a large number of instruments or in systems where proper timing is crucial. The 2251A and the 2251A-02M are capable of a variety of measurement functions. All measurement functions are dependent on the measurement signal itself. Thus, measurement cycle time will need to be calculated for each measurement signal and each measurement function used in the test program.

CALCULATING MEASUREMENT CYCLE TIME

The basic equation for all functions is as follows:

Measurement Cycle = Trigger Time + Measurement Time + Processing Time

TRIGGER TIME

Auto-trigger adds overhead to the measurement cycle time, because of the processing required to set up the trigger-level. The amount of time required for the auto-trigger is dependent on the frequency of the signal. The slower the input signal, the longer it takes for the auto-trigger to complete its determination of the signal peaks and set the trigger threshold at the correct point. The maximum amount of time is one (1) second per channel. If auto-trigger is enabled for both channels, each channel will add to the measurement cycle time regardless of whether the channel is actually utilized in the measurement process.

Auto-trigger Channel A: $\leq S$ (Frequency Dependent)

Auto-trigger Channel B: $\leq S$ (Frequency Dependent)

NOTE: Manual trigger does not add to the measurement cycle time, because the trigger-level settings are set upon receipt of the command. It does not need to wait for receipt of the signal. In most instances, auto-trigger makes up a significant portion of the total measurement cycle time. If minimum measurement cycle time is required, it is recommended that manual trigger be used.

MEASUREMENT TIME

There are four basic functions for which measurement time can be calculated: frequency/period, time interval, ratio and phase.

The equations to determine the actual measurement time for the four functions are as follows:

Frequency/Period:

Frequency/period measurement times are equivalent to the actual gate time. The actual gate time always exceeds the programmed gate time by up to 2 periods of the input signal. Thus, the total measurement time is the sum of the programmed gate time and up to two periods of the measurement signal. (See discussion of gate time following this application note).

$$\text{Meas. Time} = \text{Programmed Gate Time} + < 2 \text{ Periods of a Signal}$$

Time Interval (includes rise/fall time and pulse width):

The time interval measurement time is equivalent to the actual time interval to be measured. Thus, some idea of the time interval should be known in order to calculate the measurement time.

$$\text{Meas. Time} = 1 \text{ nS to } 8 \times 10^7 \text{ S (Signal Dependent)}$$

Ratio:

Ratio measurement time is equivalent to the actual gate time. The actual gate time always exceeds the programmed gate time by up to 2 periods of the slower input signal. Thus, the total measurement time is the sum of the programmed gate time and up to two periods of the measurement signal. (See discussion of gate time following this application note).

$$\text{Meas. Time} = \text{Programmed Gate Time} + < 2 \text{ Periods of Slower Signal}$$

Phase:

A ratio measurement, a period measurement, and a time interval measurement are performed by the counter in order to produce a phase measurement value. Thus, the phase measurement time is equivalent to the summation of three measurement times.

$$\text{Meas. Time} = \text{Ratio Meas. Time} + \text{Period Meas. Time} + \text{Time Interval Meas. Time}$$

PROCESSING TIME

After a signal has been measure, the counter requires time to process the information. The overhead introduced by the internal processing of the counter is 50 mS

Processing Time: 50 mS

MEASUREMENT CYCLE TIME

Frequency/Period Measurements

Example:

Signal Frequency: 1 KHz == > Period: 1 mS
Resolution: 9 digits == > Gate Time: 1 S
Auto-trigger Channel A: 500 mS
Processing Time: 50 mS

Meas. Time = Gate Time + 2 Period

Meas. Time = 1 S + 2 (1 mS)

Meas. Time = 1.002 S

Measurement Cycle = Processing time + Trigger Time + Meas. Time

Measurement Cycle = 50 mS = 500 mS + 1.002 S

Measurement Cycle = 1.552 S

NOTE: Frequency/period measurements do not require the enabling of auto-trigger on both input channels. Only the channel with the input signal needs to have auto-trigger enabled. This reduces the amount of overhead introduced by auto-trigger. Frequency/period measurements also allow the selection of manual trigger. This would eliminate the overhead to the measurement cycle caused by auto-trigger.

TIME INTERVAL MEASUREMENTS

Time interval measurements are highly dependent on the measurement signal. The user will need to approximate the time interval, rise/fall time, or pulse width of the measurement signal in order to calculate an approximate measurement cycle time.

NOTE: Rise/fall time and pulse width measurements require auto-trigger

EXAMPLE:

Signal Frequency: 1 MHz

Rise Time: 50 nS = == > Meas. Time: 50 nS

Auto-trigger Channel A: 500 mS

Auto-trigger Channel B: 500 mS

Processing Time: 50 mS

Measurement Cycle = Processing Time + Trigger Time + Meas. Time

Measurement Cycle = 50 mS + (500 mS + 500 mS) + 50 nS

Measurement Cycle = 1.05000005 S

RATIO MEASUREMENTS

Ratio Measurements involve frequency readings of two signals over a specified gate time.

EXAMPLE:

Signal A Frequency: 2 MHz == > Period: 0.5 S

Signal B Frequency: 1 MHz == > Period: 1 S

Programmed GateTime: 100 mS

Auto-trigger Channel A: 500 mS

Auto-trigger Channel B" 500 mS

Processing Time: 50 mS

Meas. Time = Programmed Gate Time + < 2 Periods of Slower Signal

Meas. Time = 100 mS + 2 (1 S)

Meas. Time = 100.002 mS

Measurement Cycle = Processing Time + Trigger Time + Meas. Time

Measurement Cycle = 50 mS (500 mS) + 100.001 mS

Measurement Cycle = 50 mS + 1000 mS + 100.001 mS

Measurement Cycle = 1.150002 S

PHASE MEASUREMENTS

A phase measurement consists of:

Ratio Measurement: To ensure that the two input signals are of the same frequency (within 10%)

Period Measurement: to determine the period of signals

Time Interval Measurement: To determine the time difference between two signals.

Thus, the phase measurement time consists of the summation of the above three measurement times.

For the ratio and period measurement, gate time is automatically set a 1 mS.

NOTE: A general idea of the phase characteristic or the time difference between the two signals is required in order to calculate the measurement time.

EXAMPLE:

Signal Frequency of Both channels: 1 MHz == > Period: 1 μ S

Auto-trigger Channel A: 500 mS

Auto-trigger Channel B: 500 mS

Processing Time: 50 mS

Expected Phase Difference: 90

$$\text{Phase} = [(\text{Time Interval})(360^\circ)/(\text{Period})]$$

$$\text{Time Interval} = [(\text{Phase})(\text{Period})/(360^\circ)]$$

$$\text{Time Interval} = [(90^\circ)(1 \mu\text{S})/(360^\circ)]$$

$$\text{Time Interval} = 250 \text{ nS}$$

Time Interval Meas. Time: 250 nS

Ratio Meas. Time = Gate Time + 2 Periods of Slower Signal

$$\text{Ratio Meas. Time} = 1 \text{ mS} + 2 (1 \mu\text{S})$$

$$\text{Ratio Meas. Time} = 1.002 \text{ mS}$$

Period Meas. Time = Gate Time + 2 Periods of Signal

$$\text{Period Meas. Time} = 1 \text{ mS} + 2 (1 \mu\text{S})$$

$$\text{Period Meas. Time} = 1.002 \text{ mS}$$

$$\text{Phase Meas. Time} = 1.002 \text{ mS} + 1.002 \text{ mS} = 2.004 \text{ mS}$$

$$\text{Phase Meas. Time} = 2.004250 \text{ mS}$$

Measurement Cycle = Processing Time + Trigger time + Meas. Time
Measurement Cycle = 50 mS + (500 mS + 500 mS) + 2.004250 mS
Measurement Cycle = 1.052004250 S

An examination of the measurement calculations indicate that trigger times are a significant component of the measurement cycle time. Up to 2 second of time is contributed by auto-trigger. This can be eliminated by using the manual trigger mode which does not add to the measurement cycle time.

The next major component is the gate time for frequency/period and ratio measurements. Up to 10 S can be added to the measurement cycle time if 10 digits of resolution is required. Thus, when considering measurement cycle time, the user needs to consider the trade-off between high resolution and prolonged measurement times.

SECTION 6 OPTIONAL HARNESS ASSEMBLIES

The following harness assemblies are used to connect Racal Instruments Model 2251A to Freedom Series Test Receiver Interfaces.

Each harness documentation consists of an assembly drawing, parts list, system wire list and wire list.

407298 Virginia Panel, Inc. Series VP90 Interface Harness

407299 TTI Testron Inc. Interface Harness
(TTI Receiver must be above chassis)

For more information on Racal Instruments complete line of Test Receiver Interface solutions, contact your Sales Representative.

407298		REV. 1
--------	--	--------

ZONE	REV	DESCRIPTION	DATE	APPROVED
		RELEASED PER DRN NO.		
		REVISED PER EO NO.		
		REVISED PER EO NO.		
		REVISED PER EO NO.		

- 4 SPRAY PROTECTIVE COATING (ITEM 4) AFTER MARKING.
- 5. MATING ITA CONNECTOR FOR J100 IS VIRGINIA PANEL P/N 510 108 111. USE ITA PIN P/N 610 103 115.
- 6 MARK 407298 ON APPROPRIATE SIZE SHRINK TUBING APPROXIMATELY WHERE SHOWN. PLACE APPROPRIATE SIZE CLEAR SHRINK TUBING OVER MARKING.

PROPRIETARY NOTICE
 THIS DOCUMENT AND THE TECHNICAL DATA HEREIN DISCLOSED ARE PROPRIETARY TO RACAL INSTRUMENTS, INC. NO PART OF THIS DOCUMENT IS TO BE REPRODUCED OR DISCLOSED IN ANY MANNER TO ANY OTHER PARTY WITHOUT THE WRITTEN AUTHORIZATION OF RACAL INSTRUMENTS, INC. THE INFORMATION HEREIN HAS BEEN DEVELOPED AT PRIVATE EXPENSE. IT IS HEREBY SPECIFICALLY ADVISED THAT THE INFORMATION IS NOT TO BE DISCLOSED TO ANY OTHER PARTY WITHOUT THE WRITTEN AUTHORIZATION OF RACAL INSTRUMENTS, INC. ALL INFORMATION CONTAINED HEREIN IS UNCLASSIFIED.

- NOTES:
- 1. SEE WIRE LIST FOR CONTACT ASSIGNMENTS, CONNECTIONS.
 - 2 WHITE INK STAMP J100 AT THE SIDE OF CONNECTOR AS SHOWN.
 - 3 MARK SIGNAL NAME ON APPROPRIATE SIZE SHRINK TUBING AND LOCATE APPROXIMATELY WHERE SHOWN.

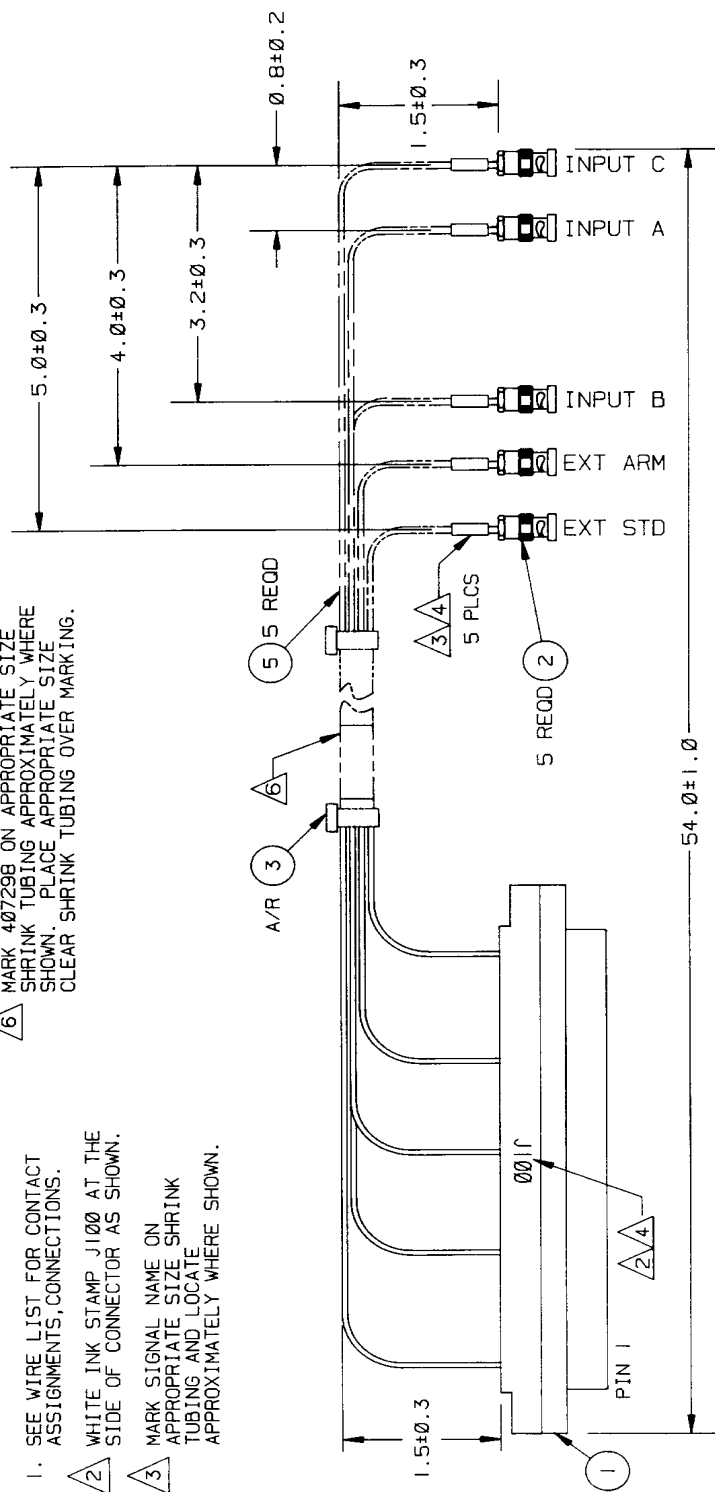

PRECISION METAL INDICATOR CODE		CONTRACT NO.	RACAL Instruments, Inc. 4 Goodyear St., Irvine, CA. 92718-2002	
WEIGHTS		APPROVALS	TITLE	
STRESS		DRAWN A. SATTERFIELD 04-09-66	HARNASS ASSY, 2251, VP90	
MATERIALS & PROCESSES		CHECKED <i>Uym</i>	SIZE	
QUALITY ASSURANCE		ENGR. <i>S.K.</i>	B	
MANUFACTURING ENGINEER		DESIGN ACTIVITY	CASE CODE	
ADDITIONAL APPROVALS			21793	
			DWG NO.	
			407298	
			REV.	
			A	
			SCALE NONE	
			DUAL/ACT/VT SHEET 1 OF 4	
			950340 REV. F	

ENGINEERING WIRE LIST

WIRE	FROM	TO	TYPE	PART #	WIRE LEN	REFERENCE
	BLK AA (J100)	Uxx-SLOT yy	CABLE	407298		SYSTEM WIRE LIST
<p>This system wirelist serves as a template for incorporating this harness assembly into the overall system wirelist. It does not in any way affect the fabrication of this harness assembly.</p>						
<p>RACAL Instruments, Inc., 4 Goodyear St., Irvine, CA 92718</p>						
DOCUMENT TITLE			SIZE	CODE NO.	DOCUMENT NO.	REV
HARNESS ASSEMBLY, 2251, VP90			A	21793	407298	A
			DRN	SHEET 3 of 4		

DOC. NO. 407298

ENGINEERING WIRE LIST

WIRE	FROM	TO	TYPE	PART #	WIRE LEN	REFERENCE	
1	J100-1 (602201-008)	EXT STD 602210	COAX	602201-807	54"	EXT STANDARD IN	
2	J100-2 (602201-008)	EXT ARM 602210	COAX	602201-807	54"	EXTERNAL ARM IN	
3	J100-3 (602201-008)	INPUT A 602210	COAX	602201-807	54"	INPUT A	
4	J100-4 (602201-008)	INPUT B 602210	COAX	602201-807	54"	INPUT B	
5	J100-5 (602201-008)	INPUT C 602210	COAX	602201-807	54"	INPUT C (Option 41)	
6	J100-6 NO CONNECT						
7	J100-7 NO CONNECT						
8	J100-8 NO CONNECT						
9	J100-9 NO CONNECT						
10	J100-10 NO CONNECT						
11	J100-11 NO CONNECT						
12	J100-12 NO CONNECT						
13	J100-13 NO CONNECT						
14	J100-14 NO CONNECT						
15	J100-15 NO CONNECT						
16	J100-16 NO CONNECT						
17	J100-17 NO CONNECT						
18	J100-18 NO CONNECT						
19	J100-19 NO CONNECT						
RACAL Instruments, Inc., 4 Goodyear St., Irvine, CA 92718							
DOCUMENT TITLE				SIZE	CODE NO.	DOCUMENT NO.	REV
HARNESS ASSEMBLY, 2251, VP90				A	21793	407298	A
				DRN	SHEET 4 of 4		

DOC. NO. 407298

407299

PROPRIETARY NOTICE
 THIS DOCUMENT AND THE DESIGN AND DRAWINGS ARE PROPRIETARY
 TO RACAL INSTRUMENTS, INC. AND SHALL NOT BE REPRODUCED, COPIED,
 TRANSMITTED, OR IN ANY MANNER DISCLOSED TO ANY OTHER PERSON,
 FIRM, OR COMPANY WITHOUT THE EXPRESS WRITTEN PERMISSION OF RACAL INSTRUMENTS, INC. THIS DOCUMENT IS THE PROPERTY
 OF RACAL INSTRUMENTS, INC. IT IS TO BE USED ONLY FOR THE MANUFACTURE,
 REPAIR, OR MAINTENANCE OF THE EQUIPMENT SPECIFICALLY IDENTIFIED
 HEREON. IT IS NOT TO BE USED FOR ANY OTHER PURPOSES. RACAL INSTRUMENTS
 AND THE RACAL LOGO ARE TRADEMARKS OF RACAL INSTRUMENTS, INC.
 ALL RIGHTS ARE RESERVED. ANY REPRODUCTION OR TRANSMISSION OF THIS
 DOCUMENT IN ANY MANNER WITHOUT THE EXPRESS WRITTEN PERMISSION OF
 RACAL INSTRUMENTS, INC. IS STRICTLY PROHIBITED. RACAL INSTRUMENTS,
 INC. MAY BE USED FOR THE PURPOSES OF ENGINEERING EVALUATION AND FOR
 SPECIFIC REPRODUCTION OF PRODUCTS THEREAFTER BY INDIVIDUALS OR
 COMPANIES WHOSE PRODUCTS ARE IDENTICAL TO THE PRODUCTS OF RACAL
 INSTRUMENTS, INC.

4 MARK 407299 ON APPROPRIATE SIZE SHRINK
 TUBING APPROXIMATELY WHERE SHOWN.
 PLACE APPROPRIATE SIZE CLEAR SHRINK
 TUBING OVER MARKING.

REVISIONS				
ZONE	REV	DESCRIPTION	DATE	APPROVED
	A	RELEASED PER DRN NO. 1546	3-16-95	L. MC
	B	REVISED AND REDRAWN PER EO NO. 24647 JF 96-12-02 J. ROBINSON		
		REVISED PER EO NO.		
		REVISED PER EO NO.		

NOTES:

- 1 MARK J--- OR SIGNAL NAME REFERENCE
 DESIGNATION ON SHRINK TUBING APPROX-
 IIMATELY WHERE SHOWN.
2. CONNECTOR PINS J100 THRU J104 WILL
 LATER INSTALL IN CONNECTOR BLOCK,
 TTI P/N VGRCB-32CP. MATING ITA
 CONNECTOR BLOCK IS P/N VGFGB-32CP.
 USE R11 PIN P/N 602227.
- 3 SPRAY PROTECTIVE COATING (ITEM 3) AFTER MARKING.

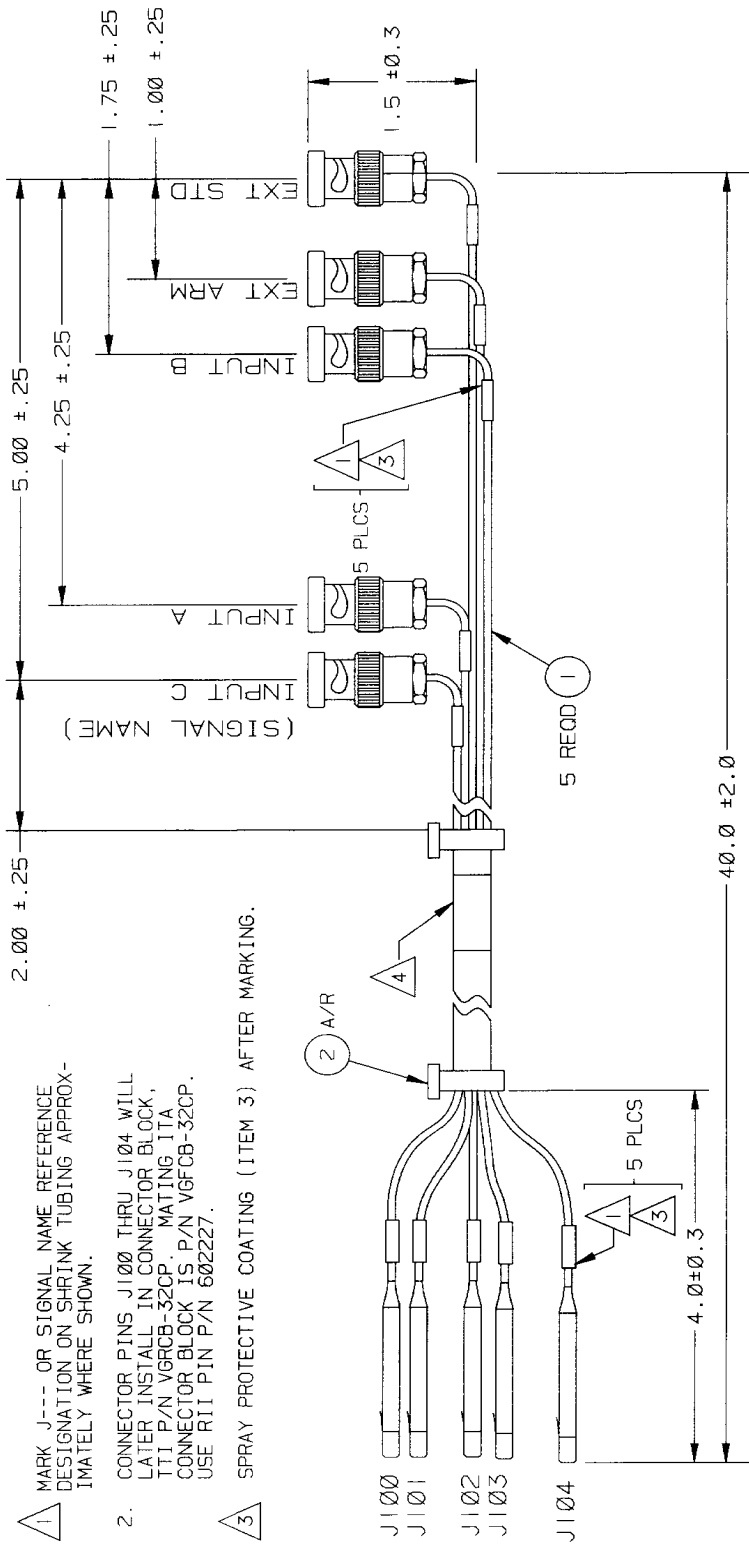

PRECIOUS METAL INDICATOR CODE			
WEIGHTS			
STRESS			
MATERIALS & PROCESSES			
QUALITY ASSURANCE	3/1/95	FREDDH	
MANUFACTURING ENGINEER			
T. VILLICANA	2/28/95		
ADDITIONAL APPROVALS	DATE		

UNLESS OTHERWISE INDICATED DIMENSIONS ARE IN INCHES DIMENSIONS IN PARENTHESISES ARE IN MILLIMETERS	CONTRACT NO.
APPROVALS	DATE
DRAWN KHANH	94-08-31
CHECKED AUSMAN	95-2-28
ENGR TIM ELMORE	95-2-28
DESIGN ACTIVITY	

RACAL Instruments, Inc.	
4 Goodyear St., Irvine, CA 92718-2002	
TITLE	
HARNES ASSY, 2251, TTI	
CASE CODE	DRG NO.
21793	407299
SCALE	NONE
CAL. BY	JVT
SHEET	1 OF 4

ENGINEERING WIRE LIST

WIRE	FROM	TO	TYPE	PART #	WIRE LEN	REFERENCE	
	BLK AAX PN 01 (J100)	Uxx-SLOT yy (INPUT C)	CABLE	407299		SYSTEM WIRE LIST	
	BLK AAX PN 02 (J101)	Uxx-SLOT yy (INPUT A)	CABLE	407299			
	BLK AAX PN 03 (J102)	Uxx-SLOT yy (INPUT B)	CABLE	407299			
	BLK AAX PN 04 (J103)	Uxx-SLOT yy (EXT ARM IN)	CABLE	407299			
	BLK AAX PN 05 (J104)	Uxx-SLOT yy (EXT STD IN)	CABLE	407299			
<p>This system wirelist serves as a template for incorporating this harness assembly into the overall system wirelist. It does not in any way affect the fabrication of this harness assembly.</p>							
<p>RACAL Instruments, Inc., 4 Goodyear St., Irvine, CA 92718</p>							
DOCUMENT TITLE				SIZE	CODE NO.	DOCUMENT NO.	REV
HARNESS ASSY, 2251, TTI				A	21793	407299	B
				DRN		SHEET 3 of 4	

DOC. NO. 407299

ENGINEERING WIRE LIST

WIRE	FROM	TO	TYPE	PART #	WIRE LEN	REFERENCE
1	J100	INPUT C (option 41)	CABLE	407262	40"	INPUT C (option 41)
2	J101	INPUT A	CABLE	407262	40"	INPUT A
3	J102	INPUT B	CABLE	407262	40"	INPUT B
4	J103	EXT ARM IN	CABLE	407262	40"	EXTERNAL ARM IN
5	J104	EXT STD IN	CABLE	407262	40"	EXTERNAL STANDARD IN
RACAL Instruments, Inc., 4 Goodyear St., Irvine, CA 92718						
DOCUMENT TITLE			SIZE	CODE NO.	DOCUMENT NO.	REV
HARNESS ASSY, 2251, TTI			A	21793	407299	B
			DRN	SHEET 4 of 4		

DOC. NO. 407299

Racal Instruments

REPAIR AND CALIBRATION REQUEST FORM

To allow us to better understand your repair requests, we suggest you use the following outline when calling and include a copy with your instrument to be sent to the Racal Repair Facility.

Model _____ Serial No. _____ Date _____

Company Name _____ Purchase Order # _____

Billing Address _____

City

State/Province

Zip/Postal Code

Country

Shipping Address _____

City

State/Province

Zip/Postal Code

Country

Technical Contact _____ Phone Number () _____

Purchasing Contact _____ Phone Number () _____

1. Describe, in detail, the problem and symptoms you are having. Please include all set up details, such as input/output levels, frequencies, waveform details, etc.

2. If problem is occurring when unit is in remote, please list the program strings used and the controller type.

3. Please give any additional information you feel would be beneficial in facilitating a faster repair time (i.e., modifications, etc.)

4. Is calibration data required? Yes No (please circle one)

Call before shipping

Ship instruments to nearest support office
listed on back.

Note: We do not accept
"collect" shipments.

Support Offices

Racal Instruments, Inc.

4 Goodyear St., Irvine, CA 92718-2002

Tel: (800) RACAL-ATE, (949) 859- 8999, FAX: (949) 859-7309

Racal Instruments, Ltd.

480 Bath Road, Slough, Berkshire, SL1 6BE, United Kingdom

Tel: +44 (0) 1628 604455; FAX: +44 (0) 1628 662017

Racal Systems Electronique

18 Avenue Dutartre, 78150 LeChesnay, France

Tel: +33 (1) 3923 2222; FAX: +33 (1) 3923 2225

Racal Systems Elettronica Srl.

Strada 2-Palazzo C4, 20090 Milanofiori Assago, Milan, Italy

Tel: +39 (02) 5750 1796; FAX +39 (02) 5750 1828

Racal Elektronik System GmbH.

Frankenforster Strasse 21, 51427 Bergisch-Gladbach 1, Germany

Tel:+49 2204 92220; FAX: +49 2204 21491

Racal Australia Pty. Ltd.

3 Powells Road, Brookvale, NSW 2100, Australia

Tel: +61 (2) 9936 7000, FAX: +61 (2) 9936 7036

Racal Electronics Pte. Ltd.

26 Ayer Rajah Crescent, 04-06/07 Ayer Rajah Industrial Estate, Singapore 0513.

Tel: +65 7792200, FAX: +65 7785400

Racal Instruments, Ltd.

Room 1213 Nan Fung Centre, Tsuen Wan, New Territories, Hong Kong

Tel: +852 2405 5500, FAX: +852 2416 4335